



METAL OXIDE VARISTORS (TNR[®])

CAT. No. E1006M

INDEX		
PRODUCT SEARCH	SERIES TABLE	➔
PRODUCTION GUIDE	PRECAUTIONS AND GUIDELINES	➔
	GROUP CHART	➔
	PART NUMBERING SYSTEM	➔
	TECHNICAL TERMS ON VARISTORS	➔
	TAPING SPECIFICATION	➔
	PACKAGING	➔
	PRODUCT SPECIFICATIONS	V Series
SE Series		➔
H Series		➔
GF Series		➔
32HP Series		➔
C Series		➔
A Series		➔
E Series		➔
PULSE LIFE TIME RATINGS		➔
APPLICATION EXAMPLES		➔



Item	Series	Features
Disk Type	V Series	Very Large Surge Capability
	SE Series	Non Flammable Type Very Large Surge Capability
	H Series	High Energy Low Voltage
	GF Series	Disk Type with Thermal Fuse
	32HP Series	High Energy with Heat Sink
Chip Type	C Series	Single Layer Chip Type Direct Surface Mounting
Axial Lead Type	A Series	Axial Lead Type High Voltage
Case Type	E Series	Case Type High Energy

- 1** The performance of varistors may deteriorate, the inside elements may be damaged, and they cause the varistors to smoke or catch fire, if the following precautions are not observed.
 - (1) Do not use varistors in places whose temperature exceeds their rated operating temperature due to direct sunlight or heating objects.
 - (2) Do not use varistors in a humid place directly exposed to the weather or steam.
 - (3) Do not use varistors in places filled with dust, salt-mist or corrosive gas.
 - (4) Apply soldering conditions within the limits prescribed in the catalog or product specifications.
For surface mount varistors, use flux with a halogen content of less than 0.2 wt.%. Do not use strong acid flux.
 - (5) Do not use solvents such as thinner and acetone which dissolve or make the exterior covering of varistors deteriorate.
Ultrasonic cleaning shall be so set that the vibration can not travel the assembly boards.
 - (6) Do not expose varistors to intense vibration, shock (drop shock etc.) or pressure making the exterior covering or inside element crack.
 - (7) Do not apply high voltage exceeding the rated maximum applying voltage to varistors.
In the case of automotive jump starts, however, use the varistors within short-term allowable voltage limits prescribed in the catalog.
If voltage wave form is not complete DC, a maximum value of peak voltages shall not exceed the rated maximum applying voltage.
 - (8) Do not apply peak currents exceeding the rated maximum energy.
 - (9) When peak currents are repeatedly applied to varistors, do not exceed the pulse life time ratings prescribed in the catalog.
 - (10) When peak currents are intermittently applied to varistors at short intervals, do not exceed the rated wattage.
 - (11) Using varistors in circuits whose frequency exceeds 1kHz may damage their elements by heat generation due to dielectric loss.
 - (12) In the case of coating or molding varistors with resin, do not use the resin which makes the varistors deteriorate.
 - (13) Do not install varistors in places near by flammable substances.
- 2** Varistors may blow up, if the following precautions are not observed.
 - (1) Do not use varistors in circuits applied peak currents exceeding the specified limits.
 - (2) Do not exceed the rated maximum applying voltage.
- 3** Varistors do not function but damages devices, if the following precautions are not observed.
 - (1) Hold the root of the varistor lead when bending or cutting the lead.
 - (2) The lead close to insulation cover shall not be bent or applied to outer force.
 - (3) When soldering the lead, do not damage a solder material and insulator fabricating the varistor.
 - (4) Put the proper volume of solder (the height of fillet) on pc boards for installing surface mount varistors, because it directly affects the installed varistors. The design of copper pad patterns and dimensions should be set so that the proper volume of solder can be provided.
 - (5) When mounting surface mount varistors on the pc board, the improper soldering temperature and time out of the limits may reduce the adhesive strength of their terminals.
 - (6) When cutting off a multi-board to make individual units, curving or twisting the board may make the varistors crack. Appropriate tools should be used to cut it off.
- 4** The following preventive measures should be made for avoiding unexpected accident.
 - (1) When using a varistor in between circuits, connect an earth leakage breaker (ground-fault circuit interrupter) or current fuse in series with the varistor.
 - (2) When using a varistor in between a circuit and ground, connect an earth leakage breaker (ground-fault circuit interrupter) or both of a current fuse and thermal fuse in series with the varistor. Also, in case of excessive voltage due to ground short circuit accident, use the varistor with the rated voltage higher than the excessive voltage.
- 5** Store varistors at a temperature of -10 to $+40^{\circ}\text{C}$ and a relative humidity of less than 75%.
Avoid storing in environment of rapid changes in temperature, direct sunlight, corrosive gas or dust, and store with the varistors packaged and use within 1 year.
Please confirm soldering of the lead wire with the product stored in a long time in more than 1 year.
- 6** Follow safety standards such as Electrical, UL, CSA and so forth, which specify the use of varistors.
- 7** Catalogs
Specifications in catalogs may be subject to change without notice.
Performance test data in the catalogs show typical values, which are not assured in the catalogs.

TNR is a "NEW" metal oxide varistor having steep non-linear V-I characteristics and high discharge current capability, as follows:

◆TNR Features

1. Excellent transient voltage suppression
2. High discharge current capability
3. Wide range of voltage ratings
4. Symmetrical V-I characteristics (Non Polarity)
5. Fast response
6. Steady operation for repeating surge
7. Low temperature coefficient
8. High reliability
9. UL recognized
10. CSA recognized

◆Applications

1. Electronics instrument protection
2. Telephone system protection
3. Relay contact point protection
4. Rectification diode protection
5. SCR protection
6. Reduction of abnormal voltage in high voltage current
7. Switching transistor protection
8. Reduction of switching surge in electromagnetic brake
9. Prevention of error in digital circuit
10. Reduction of noise from an abnormal voltage

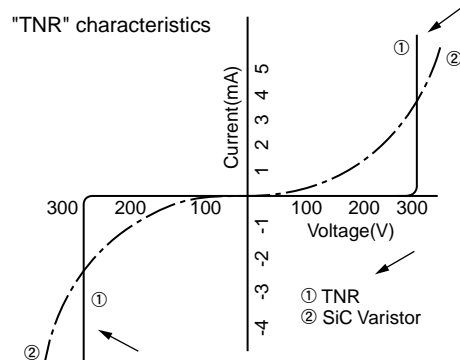

◆Group Chart

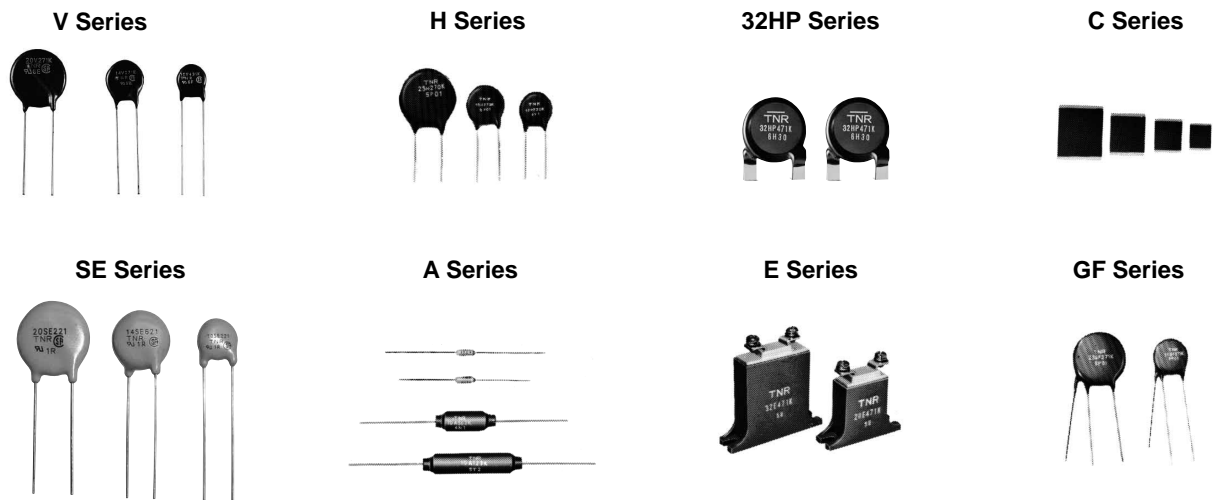

◆Part Numbering System

The current parts numbering system is changed to new system for global coding. Your cooperation will be very much appreciated.

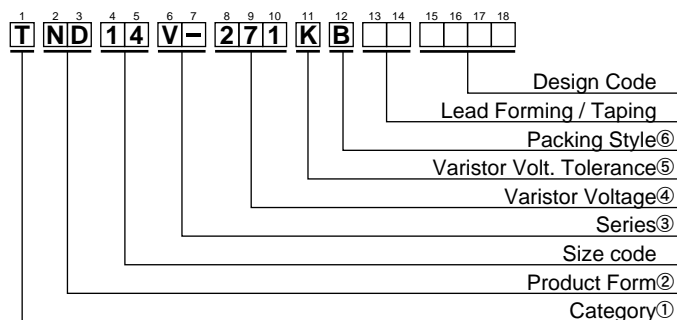

①Category	
T	Metal Oxide Varistors TNR
②Product Form	
ND	DISK Type
NC	Chip Type
NL	Sleeve Type
③Series	
V-	V Series

④Varistor Voltage	
The first two digits are significant figures and the third one denotes the number of following zeros.	
⑤Varistor Volt. Tolerance	
K	±10%
⑥Packing Style	
B	Bulk
T	Taping

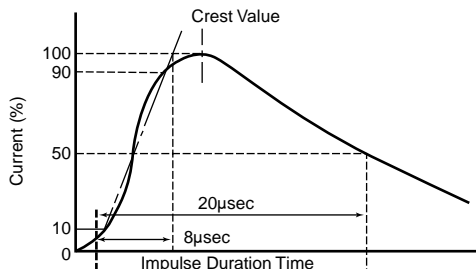
Technical Term	Description
Varistor Voltage	Voltage across the varistor measured at CmA DC. C = 0.1 or 1.0 as specified.
Applied Voltage (ACrms)	Maximum continuous sinusoidal RMS voltage which may be applied.
Applied Voltage (DC)	Maximum continuous DC voltage which may be applied.
Maximum Clamping Voltage	Peak voltage across the varistor, measured under conditions of a specified peak impulse current and specified waveform (8/20 μ sec.) applied 1 time.
Rated Wattage	Maximum power that can be applied within the specified ambient temperature.
Maximum Peak Current	Maximum current within the $\pm 10\%$ varistor voltage change with standard impulse current (8/20 μ sec.) applied 1time.
Current Wave Form for Clamping Voltage Test and Maximum Peak Current	
Energy	Maximum energy within the $\pm 10\%$ varistor voltage change when 1 impulse τ msec long is applied. $\tau = 2$ or 20 or 200 ms as specified.
Capacitance	Typical value measured at a 1kHz test frequency. (Sinusoidal wave. Reference purpose only)

- This Specifies taping specifications for TNR varistors which have normal disk diameter of 5 to 15mm and nominal varistor voltage of 15 to 470V.
- These taping specifications conform to JIS C 0805.

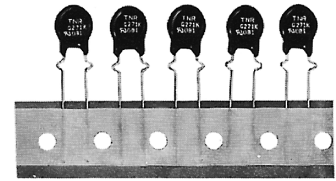

◆PART NUMBERING SYSTEM

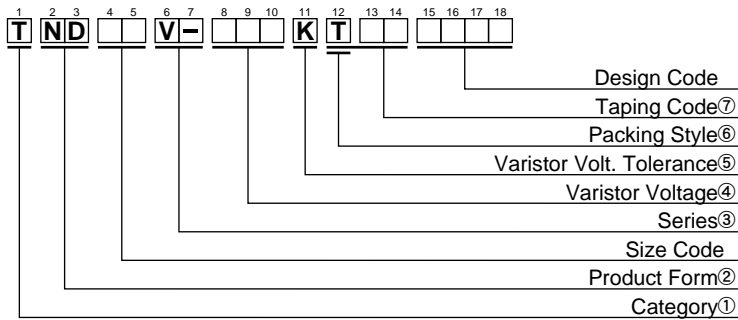

①Category	
T	Metal Oxide Varistor TNR

②Product Form	
ND	DISK Type

③Series	
V-	V Series
H-	H Series
SE	SE Series

④Varistor Voltage	
The first two digits are significant figures and the third one denotes the number of following zeros.	

⑤Varistor Volt. Tolerance	
K	±10%

⑥Packing Style	
T	Taping

⑦Taping Code							
Package	Type	Lead Style (Feed hole pitch : 12.7mm)				Lead Style (Feed hole pitch : 15.0mm)	
		Crimped	Crimped(Parallel)	Straight	Straight(Parallel)	Crimped(Parallel)	Straight(Parallel)
Box	5V,7V,9V,9H		TFA(T15)		TBA(T25)		
	10V,14V	TEA(T1)	TFA(T15)	TAA(T2)	TBA(T25)	TFB(T8)	TBB(T7)
	10SE,14SE	TEA(T1)	TFA(T15)	TAA(T2)	TBA(T25)	TFB(T8)	TBB(T7)
	12H,15H	TEA(T1)	TFA(T15)	TAA(T2)	TBA(T25)		

Note : The code(T1, T15, T2, T25, T8, T7) are the old taping code.

◆Details of Taping Code

Digits	Code	Lead Style & Feed hole pitch
13	A	Straight Lead, Form-A
	B	Straight Lead, Form-B
	E	Crimped Lead, Form-A
	F	Crimped Lead, Form-B
14	A	Feed hole pitch : 12.7mm, Box
	B	Feed hole pitch : 15.0mm, Box



Form-A

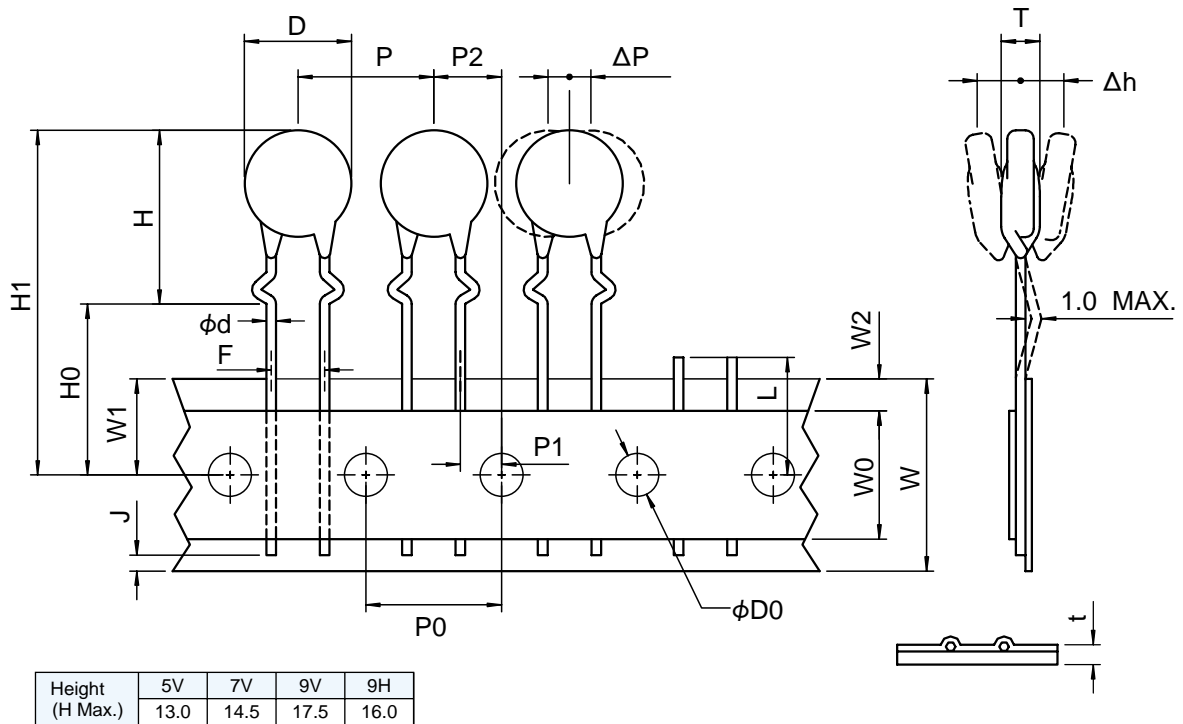

Form-B (Parallel)

◆5V, 7V, 9V, 9H : TYPE TFA(T15) (Crimped Lead)

◆5V, 7V, 9V, 9H : TYPE TFA(T15)

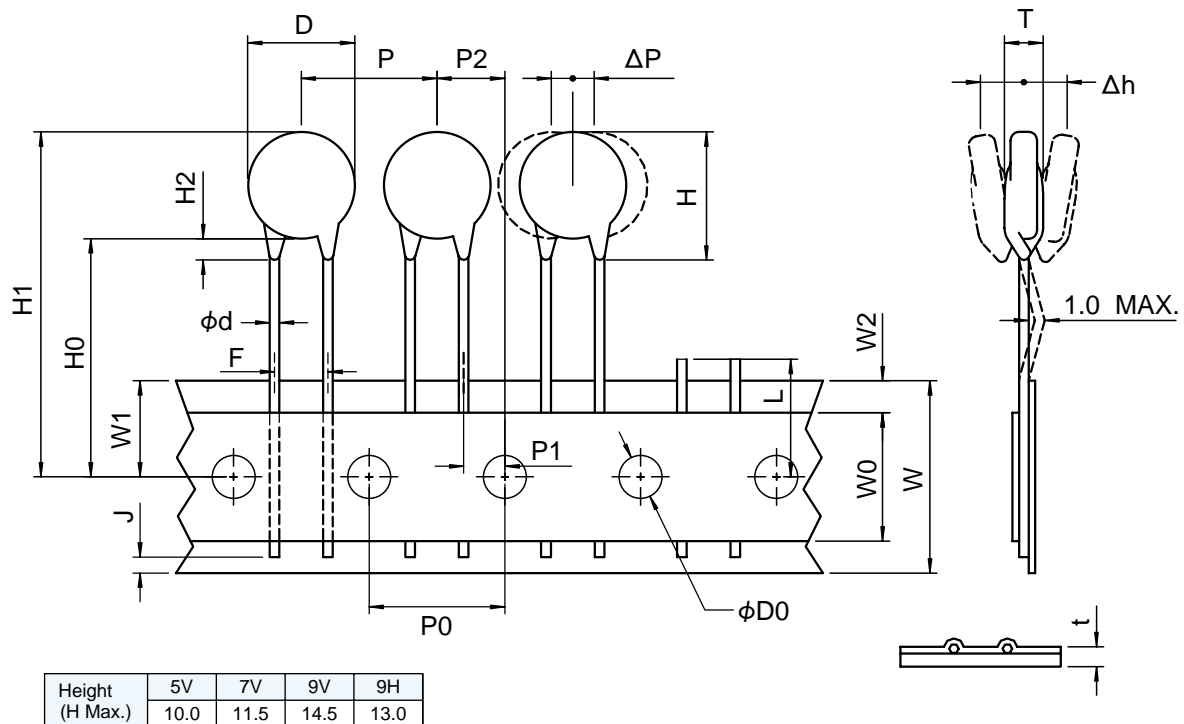
Parameter	Code	Dimensions (mm)	Note
Diameter of component	D	—	Refer to the applicable detail spec
Thickness of component	T	—	Refer to the applicable detail spec
Lead diameter	ϕd	0.6±0.05	
Pitch of component	P	12.7±1.0	
Feed hole pitch	P0	12.7±0.3	Cumulative pitch error : ±1 mm/20 pitches
Feed hole diameter	$\phi D0$	4.0±0.2	
Feed hole center to lead	P1	3.85±0.7	Measured at the upper end of tape
Feed hole center to component center	P2	6.35±1.3	
Feed hole position	W1	9.0±0.5	
Lead spacing	F	5.0±0.8	
Deviation across tape	Δh	0±2.0	
Deviation along tape	ΔP	0±1.0	
Carrier tape width	W	18.0± $\begin{smallmatrix} 0.8 \\ 0.8 \end{smallmatrix}$	
Hold down tape width	W0	5.0 Min.	
Total tape thickness	t	0.6±0.3	
Hold down tape position	W2	3.0 Max.	
Seating plane height	H0	16.0±0.5	
Component height	H1	32.2 Max.	9V : 34.0 Max.
Lead position	J	6.0 Max.	

◆ 5V, 7V, 9V, 9H : TYPE TBA(T25) (Straight Lead)

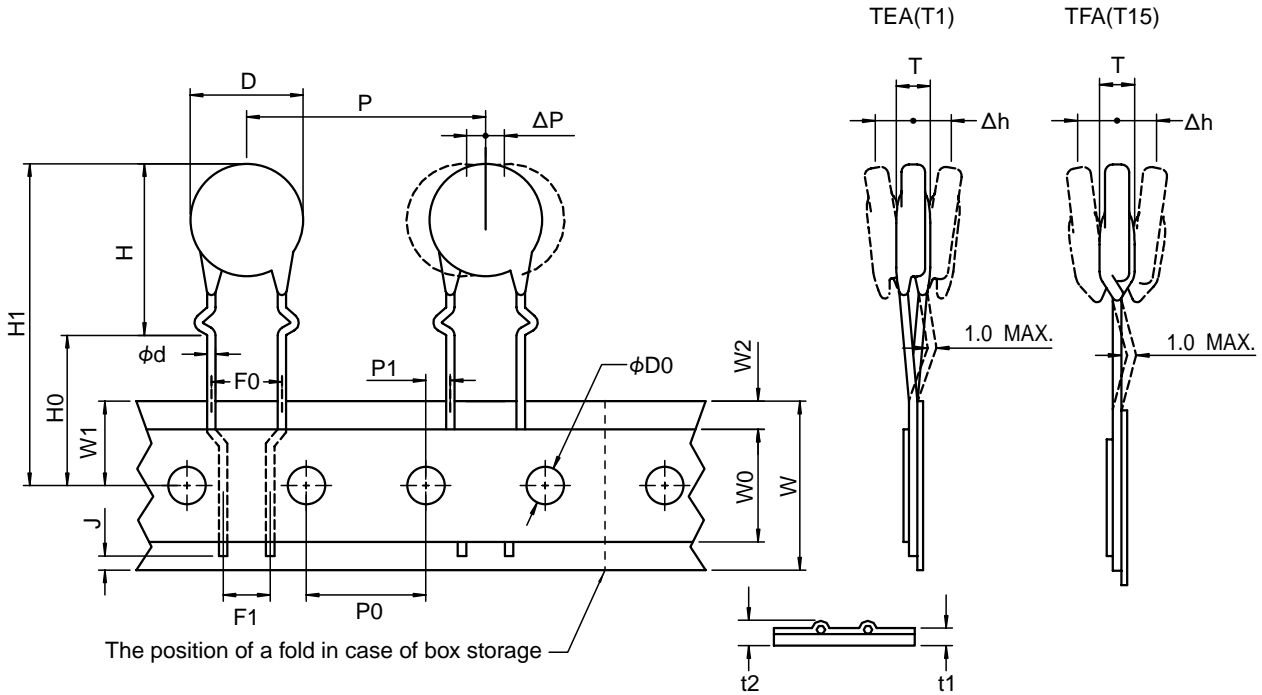
◆ 5V, 7V, 9V, 9H : TYPE TBA(T25)

Parameter	Code	Dimensions (mm)	Note
Diameter of component	D	—	Refer to the applicable detail spec
Thickness of component	T	—	Refer to the applicable detail spec
Lead diameter	φd	0.6±0.05	
Pitch of component	P	12.7±1.0	
Feed hole pitch	P0	12.7±0.3	Cumulative pitch error : ±1 mm/20 pitches
Feed hole diameter	φD0	4.0±0.2	
Feed hole center to lead	P1	3.85±0.7	Measured at the upper end of tape
Feed hole center to component center	P2	6.35±1.3	
Feed hole position	W1	9.0±0.5	
Lead spacing	F	5.0±0.8	
Deviation across tape	Δh	0±2.0	9V : 34.0 Max.
Deviation along tape	ΔP	0±1.0	
Carrier tape width	W	18.0± $\frac{0.0}{0.5}$	
Hold down tape width	W0	5.0 Min.	
Total tape thickness	t	0.6±0.3	
Hold down tape position	W2	3.0 Max.	
Height from tape center to component base	H0	20.0± $\frac{1.5}{0.5}$	
Component height	H1	32.2 Max.	
Lead position	J	6.0 Max.	

◆10V, 14V, 10SE, 14SE, 12H, 15H : TYPE TEA(T1), TFA(T15) (Crimped Lead)

Height (H Max.)	10V	14V	10SE	14SE	12H	15H
	17.5	21.0	21.0	25.0	21.0	24.0

◆10V, 14V, 10SE, 14SE, 12H, 15H : TYPE TEA(T1), TFA(T15)

Parameter	Code	Dimensions (mm)	Note
Diameter of component	D	—	Refer to the applicable detail spec
Thickness of component	T	—	Refer to the applicable detail spec
Lead diameter	φd	0.8±0.05	
Pitch of component	P	25.4±1.0	
Feed hole pitch	P0	12.7±0.3	Cumulative pitch error : ±1 mm/20 pitches
Feed hole diameter	φD0	4.0±0.2	
Feed hole center to lead	P1	2.6±0.5	Measured at the upper end of tape
Feed hole position	W1	9.0±0.5	
Lead spacing	F0	7.5±0.8	
	F1	5.0 Nom.	
Deviation across tape	Δh	0±2.0	
Deviation along tape	ΔP	0±1.0	
Carrier tape width	W	18.0±0.5	
Hold down tape width	W0	5.0 Min.	
Total tape thickness	t	0.6±0.3	
Hold down tape position	W2	3.0 Max.	
Seating plane height	H0	16.0±1.0	
Component height	H1	41.0 Max.	
Lead position	J	6.0 Max.	

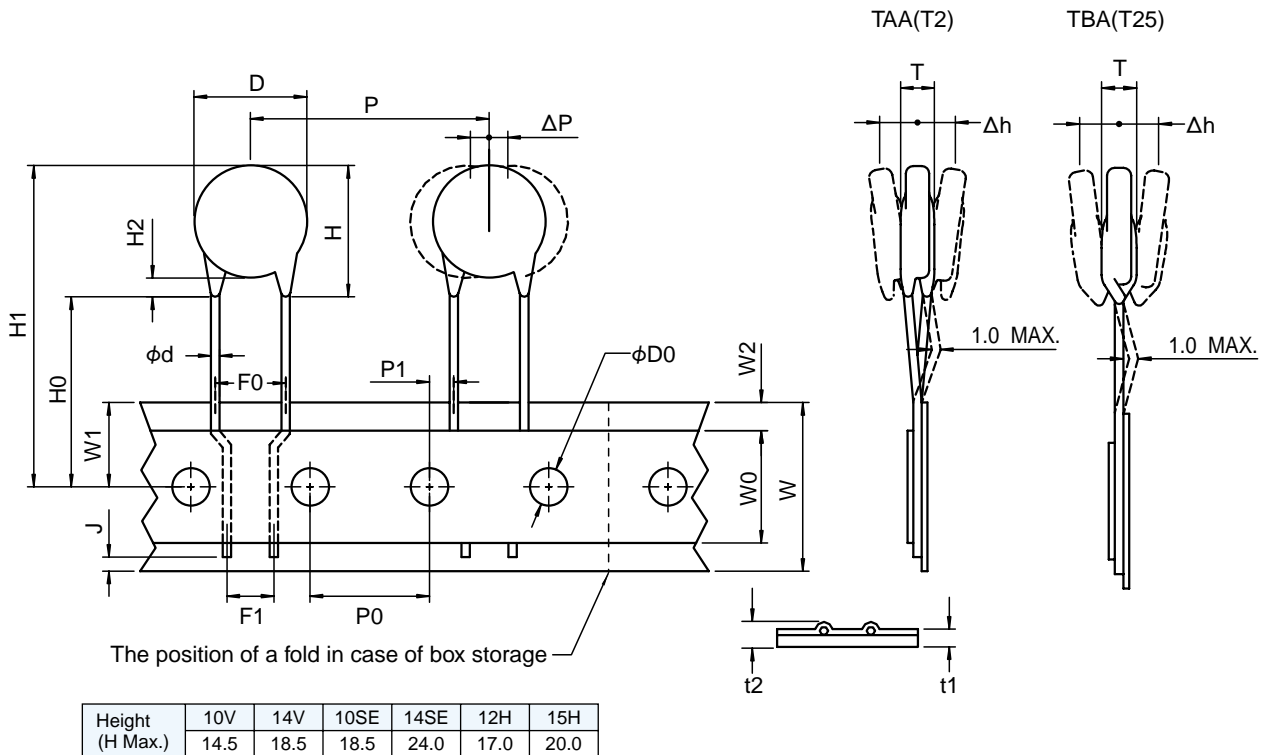
◆10V, 14V, 10SE, 14SE, 12H, 15H : TYPE TAA(T2), TBA(T25) (Straight Lead)

◆10V, 14V, 10SE, 14SE, 12H, 15H : TYPE TAA(T2), TBA(T25)

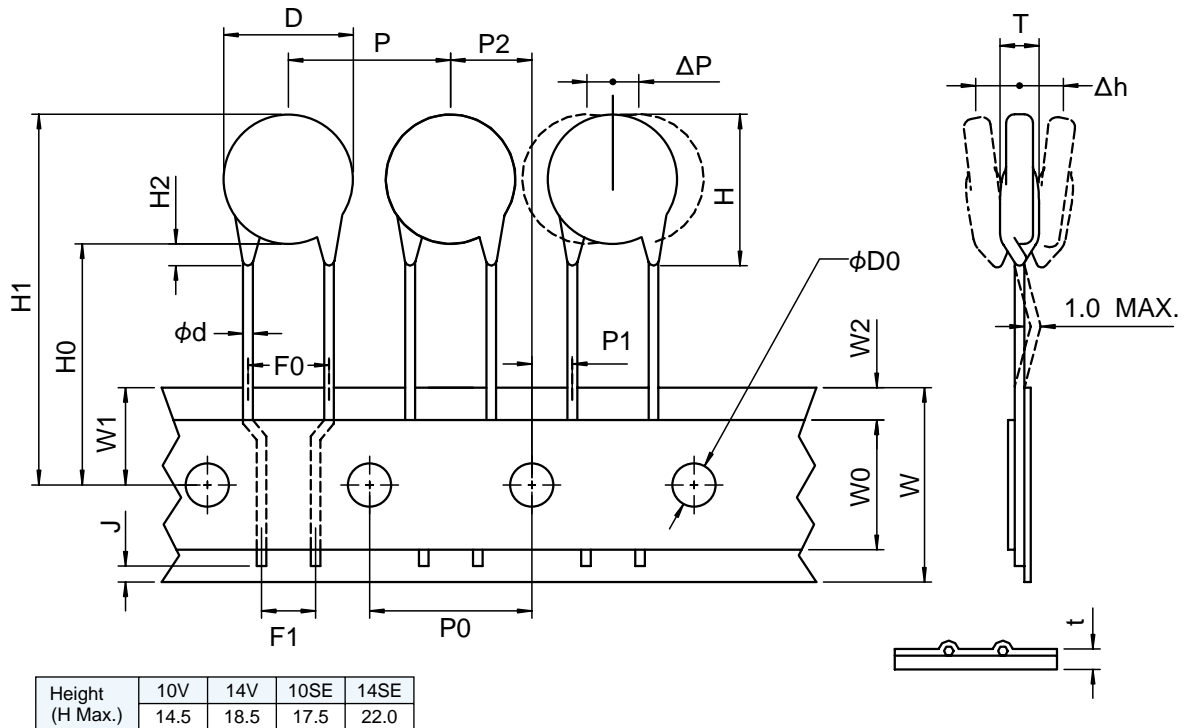
Parameter	Code	Dimensions (mm)	Note
Diameter of component	D	—	Refer to the applicable detail spec
Thickness of component	T	—	Refer to the applicable detail spec
Lead diameter	ϕd	0.8±0.05	
Pitch of component	P	25.4±1.0	
Feed hole pitch	P0	12.7±0.3	Cumulative pitch error : ±1 mm/20 pitches
Feed hole diameter	$\phi D0$	4.0±0.2	
Feed hole center to lead	P1	2.6±0.5	Measured at the upper end of tape
Feed hole position	W1	9.0±0.5	
Lead spacing	F0	7.5±0.8	
	F1	5.0 Nom.	
Deviation across tape	Δh	0±2.0	
Deviation along tape	ΔP	0±1.0	
Carrier tape width	W	18.0±0.5	
Hold down tape width	W0	5.0 Min.	
Total tape thickness	t	0.6±0.3	
Hold down tape position	W2	3.0 Max.	
Height from tape center to component base	H0	20.0 Min.	SE : 19.0 Min.
Component height	H1	41.0 Max.	
	H2	3.0 Max.	
Lead position	J	6.0 Max.	

◆10V, 14V, 10SE, 14SE : TYPE TBB(T7) (Straight Lead, 15mm Pitch)

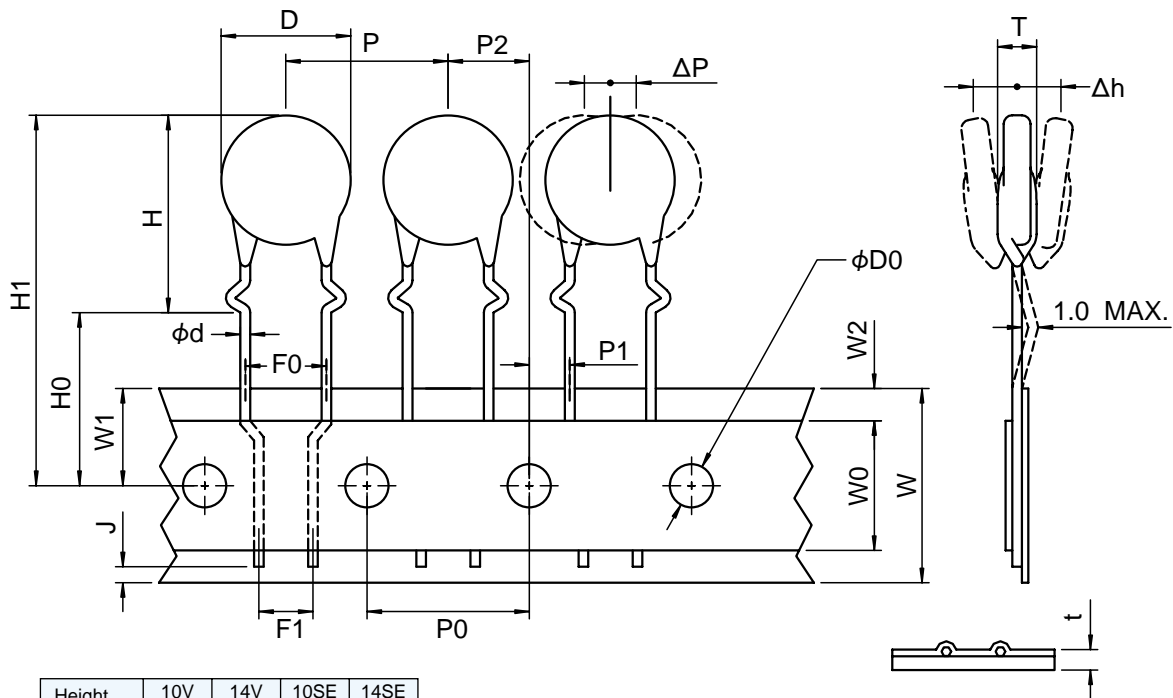
◆10V, 14V : TYPE TBB(T7)

Parameter	Code	Dimensions (mm)	Note
Diameter of component	D	—	Refer to the applicable detail spec (14V : 15.0 Max.)
Thickness of component	T	—	Refer to the applicable detail spec
Lead diameter	φd	0.8±0.05	
Pitch of component	P	15.0±1.0	14SE : 30.0 ±1.0 mm
Feed hole pitch	P0	15.0±0.3	Cumulative pitch error : ±1 mm/20 pitches
Feed hole diameter	φD0	4.0±0.2	
Feed hole center to lead	P1	3.75±0.5	Measured at the upper end of tape
Feed hole center to component center	P2	7.5±1.3	
Feed hole position	W1	9.0±0.5	
Lead spacing	F0	7.5±0.8	
	F1	5.0 Nom.	
Deviation across tape	Δh	0±2.0	
Deviation along tape	ΔP	0±1.3	
Carrier tape width	W	18.0± ^{1.0} _{0.5}	
Hold down tape width	W0	5.0 Min.	
Total tape thickness	t	0.6±0.3	
Hold down tape position	W2	3.0 Max.	
Height from tape center to component base	H0	20.0± ^{1.0} _{1.0}	
Component height	H1	41.0 Max.	
	H2	3.0 Max.	
Lead position	J	6.0 Max.	

◆10V, 14V, 10SE, 14SE : TYPE TFB(T8) (Crimped Lead, 15mm Pitch)

Height (H Max.)	10V	14V	10SE	14SE
	17.5	21.0	20.0	23.0

◆10V, 14V : TYPE TFB(T8)

Parameter	Code	Dimensions (mm)	Note
Diameter of component	D	—	Refer to the applicable detail spec (14V : 15.0 Max.)
Thickness of component	T	—	Refer to the applicable detail spec
Lead diameter	φd	0.8±0.05	
Pitch of component	P	15.0±1.0	14SE : 30.0±1.0 mm
Feed hole pitch	P0	15.0±0.3	Cumulative pitch error : ±1 mm/20 pitches
Feed hole diameter	φD0	4.0±0.2	
Feed hole center to lead	P1	3.75±0.5	Measured at the upper end of tape
Feed hole center to component center	P2	7.5±1.3	
Feed hole position	W1	9.0±0.5	
Lead spacing	F0	7.5±0.8	
	F1	5.0 Nom.	
Deviation across tape	Δh	0±2.0	
Deviation along tape	ΔP	0±1.3	
Carrier tape width	W	18.0± ^{1.0} _{0.5}	
Hold down tape width	W0	5.0 Min.	
Total tape thickness	t	0.6±0.3	
Hold down tape position	W2	3.0 Max.	
Seating plane height	H	—	10V ; 17.5 Max. 14V ; 21.0 Max.
	H0	16.0±1.0	
Component height	H1	41.0 Max.	
Lead position	J	6.0 Max.	

◆Packaging

		B o x			
Configuration					
	Dimensions (mm)		TFA, TBA (T15, T25)	TEA, TFA, TAA, TBA (T1, T15, T2, T25)	TFB, TBB (T8, T7)
		5V, 7V, 9V, 9H	10V, 14V, 12H, 15H	10SE, 14SE	10V, 14V, 10SE, 14SE
	W	325±5	330±5	340 max.	340 max.
	H	47±3	57±3	65 max.	65 max.
	B	280±10	315±10	360 max.	360 max.

◆Packaging Quantity

Type	Taping Code	150K~271K	331K~511K
5V,7V,9V,9H	TFA, TBA(T15, T25)	1,500	1,000
10V,14V	TEA, TFA, TAA, TBA	800	500
10SE,14SE	(T1, T15, T2, T25)	600	500
12H,15H		800	/
10V,14V	TFB, TBB	1,000	1,000
10SE	(T8, T7)	1,000	800
14SE		500	400

NOTE : The code (T1, T15, T2, T25, T8, T7) are the old taping code

◆Others

- 1) On the box or the reel, followings are noted.
 1. Model number
 2. Lot number
 3. Quantity
 4. Country of origin
- 2) Minimum order quantity shall be the packaging quantity per one box one reel.

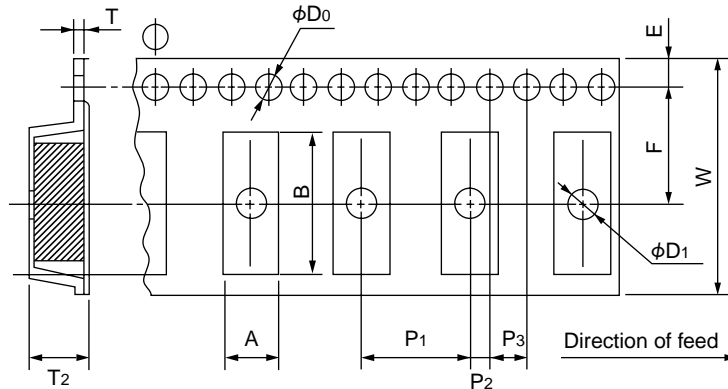
◆THE SPECIFICATIONS for TNR C Series

Type	Dimensions (mm)											
	A	B	W	F	E	P ₁	P ₂	P ₃	φD ₀	T	T ₂	φD ₁
5C-A	±0.1	±0.1	±0.3	±0.1	±0.1	±0.1	±0.1	±0.1	+0.1 0	Max.	Max.	Min.
5C-B	6.9	10.4				8.0						
7C	6.85	8.05				12.0						
9C	8.3	10.6	24.0	11.5	1.75	2.0	4.0	1.5	0.6	3.0	3.5	1.5
12C	10.85	13.0										
12C	12.5	16.3										

◆REEL

Type	Rating of varistor
5C-A	TNC05C-220K~470K, TNC05C-820K~271K
5C-B	TNC05C-560K, 680K

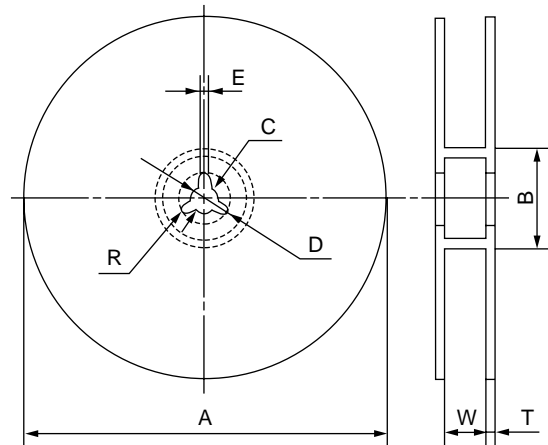

Type	Dimensions (mm)							
	A	B	C	D	E	W	T	R
5C-A, 5C-B	±0.2	Min.	±0.5	±0.8	±0.5	±1.0	±0.5	Nom.
7C	330	50	13	21	2.0	17.4	2.0	1.0
9C						25.4		
12C								

◆STANDARD PACKING QUANTITY PER REEL

(Unit : Pcs)

Type	5C-A	5C-B	7 C	9 C	12C
Quantity	3500	2000	2000	1500	1000

V Series

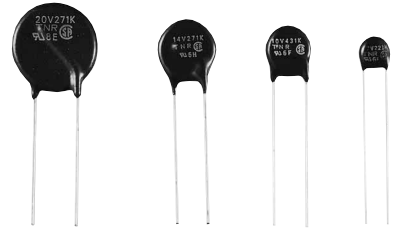

◆FEATURES

- Large surge capability (the surge current ratings of TNR V series, by 8/20 μ Sec., are about two times larger than TNR G series).
- Large energy capability (1.5 time larger than TNR G series).
- One rank smaller TNR V has same peak current as TNR G.
- Excellent voltage non-linear coefficient.
Low clamping voltage.
- Symmetrical V-I characteristics (No polarity).
- Fast response.
- Stable characteristics against repeated surges.
- Superior temperature characteristics.
- High reliability
- UL recognized
UL 1449 : File E95427
UL 1414 : File E65426
- CSA recognized
CSA CLASS 2221 01 : File LR 97864-2
- VDE recognized
CECC42000/CECC42200/CECC42201
License No. : 118623 ÜG (Japan), 40006627 (Indonesia)

◆APPLICATIONS

- Protection for semiconductors from over voltage.
- Protection for electronic instruments from lightning surges.
- Absorption of on-off surges from motors and relays.

Operating Temperature Range: -40~+85°C

Storage Temperature Range: -50~+125°C

◆PART NUMBERING SYSTEM

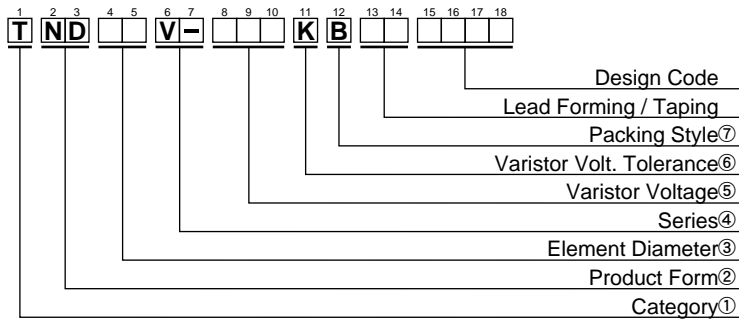

①Category	
T	Metal Oxide Varistors TNR

②Product Form	
ND	DISK Type

③Element Diameter	
05	φ 5mm
07	φ 7mm
09	φ 9mm
10	φ10mm
14	φ14mm
20	φ20mm

④Series	
V-	V Series

⑤Varistor Voltage
The first two digits are significant figures and the third one denotes the number of following zeros.

⑥Varistor Volt. Tolerance	
K	±10%

⑦Packing Style	
B	Bulk
T	Taping



V Series

◆STANDARD RATINGS (Type 5V)

Part Number	Previous Part Number (Just for your reference)	Maximum Ratings					Max. Clamping Voltage		Capacitance Typical @1kHz (pF)	Varistor Voltage V _{0.1mA} (V)	T Max. (mm)
		Max. Allowable Voltage		Max. Peak Current	Max. Energy	Rated Wattage	(A)	(V)			
		AC (Vrms)	DC (V)	8/20μs(A)	2ms(J)	(W)					
TND05V-180KB00AAA0	TNR5V180K	11	14	250A/1 time 125A/2 times	0.4	0.01	1	40	2,540	18 (16~ 20)	4.5
TND05V-220KB00AAA0	TNR5V220K	14	18		0.5			48	2,090	22 (20~ 24)	
TND05V-270KB00AAA0	TNR5V270K	17	22		0.7			60	1,790	27 (24~ 30)	
TND05V-330KB00AAA0	TNR5V330K	20	26		0.8			73	1,480	33 (30~ 36)	
TND05V-390KB00AAA0	TNR5V390K	25	30		0.9			86	1,310	39 (35~ 43)	
TND05V-470KB00AAA0	TNR5V470K	30	37		1.1			104	1,140	47 (42~ 52)	
TND05V-560KB00AAA0	TNR5V560K	35	44		1.3			123	1,000	56 (50~ 62)	
TND05V-680KB00AAA0	TNR5V680K	40	55	1.6	150	870	68 (61~ 75)				
TND05V-820KB00AAA0	TNR5V820K	50	65	800A/1 time 600A/2 times	2.5	0.1	5	145	400	82 (74~ 90)	4.1
TND05V-101KB00AAA0	TNR5V101K	60	85		3			175	350	100 (90~110)	4.3
TND05V-121KB00AAA0	TNR5V121K	75	100		3.5			210	310	120 (108~132)	4.5
TND05V-151KB00AAA0	TNR5V151K	95	125		4.5			260	270	150 (135~165)	4.8
TND05V-181KB00AAA0	TNR5V181K	110	145		5			325	190	180 (162~198)	4.3
TND05V-201KB00AAA0	TNR5V201K	130	170		6			355	110	200 (185~225)	4.4
TND05V-221KB00AAA0	TNR5V221K	140	180		6.5			380	110	220 (198~242)	4.5
TND05V-241KB00AAA0	TNR5V241K	150	200		7.5			415	100	240 (216~264)	4.6
TND05V-271KB00AAA0	TNR5V271K	175	225		8			475	90	270 (247~303)	4.8
TND05V-331KB00AAA0	TNR5V331K	210	270		9.5			570	80	330 (297~363)	5.1
TND05V-361KB00AAA0	TNR5V361K	230	300		11			620	80	360 (324~396)	5.3
TND05V-391KB00AAA0	TNR5V391K	250	320		12			675	70	390 (351~429)	5.4
TND05V-431KB00AAA0	TNR5V431K	275	350		13.5			745	70	430 (387~473)	5.6
TND05V-471KB00AAA0	TNR5V471K	300	385		15			810	60	470 (423~517)	5.8

◆DIMENSIONS [mm]

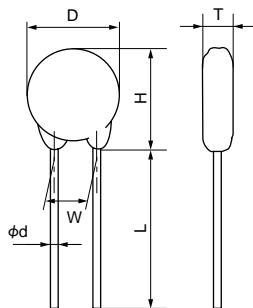

D Max.	H Max.	T Max.	L Min.	φd ±0.05	W ±1.0
7.0	10.0	Ref. to RATINGS	20.0	0.6	5.0

◆V-I CURVE

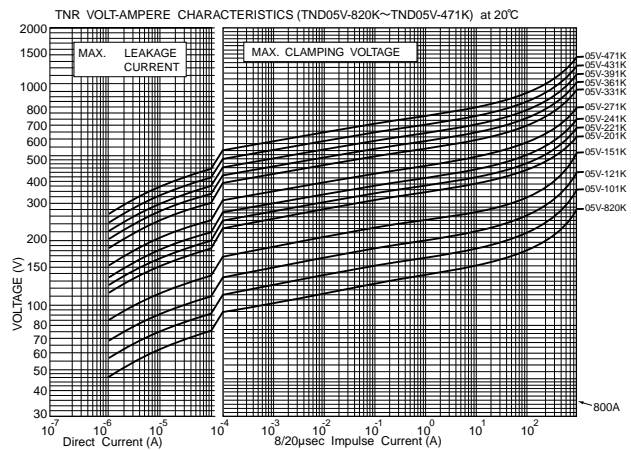
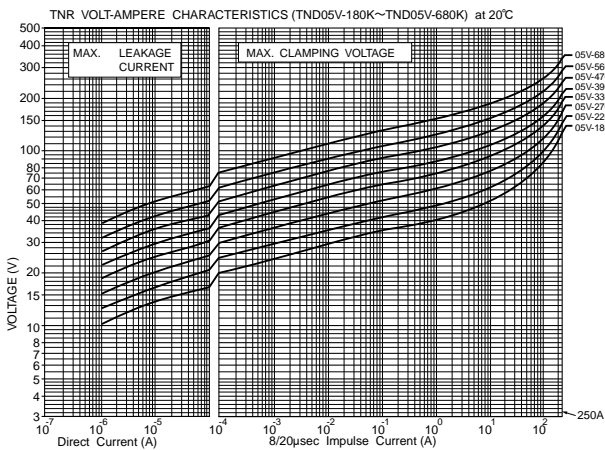

V Series

◆STANDARD RATINGS (Type 7V)

Part Number	Previous Part Number (Just for your reference)	Maximum Ratings					Max. Clamping Voltage		Capacitance Typical @1kHz (pF)	Varistor Voltage V _{1mA} (V)	T Max. (mm)
		Max. Allowable Voltage		Max. Peak Current	Max. Energy	Rated Wattage	(A)	(V)			
		AC (Vrms)	DC (V)	8/20μs(A)	2ms(J)	(W)					
TND07V-150KB00AAA0	TNR7V150K	8	12		0.7			30	4,600	15 (13~ 17)	4.5
TND07V-180KB00AAA0	TNR7V180K	11	14		0.9			36	3,800	18 (16~ 20)	4.5
TND07V-220KB00AAA0	TNR7V220K	14	18		1.1			43	3,200	22 (20~ 24)	4.6
TND07V-270KB00AAA0	TNR7V270K	17	22	500A/1 time	1.3			53	2,800	27 (24~ 30)	4.7
TND07V-330KB00AAA0	TNR7V330K	20	26		1.6	0.02	2.5	65	2,300	33 (30~ 36)	4.9
TND07V-390KB00AAA0	TNR7V390K	25	30	250A/2 times	1.9			77	2,100	39 (35~ 43)	4.8
TND07V-470KB00AAA0	TNR7V470K	30	37		2.3			93	1,900	47 (42~ 52)	4.9
TND07V-560KB00AAA0	TNR7V560K	35	44		2.7			110	1,700	56 (50~ 62)	5.0
TND07V-680KB00AAA0	TNR7V680K	40	55		3.3			135	1,500	68 (61~ 75)	5.2
TND07V-820KB00AAA0	TNR7V820K	50	65		5			135	800	82 (74~ 90)	4.1
TND07V-101KB00AAA0	TNR7V101K	60	85		6			165	700	100 (90~110)	4.3
TND07V-121KB00AAA0	TNR7V121K	75	100		7			200	650	120 (108~132)	4.5
TND07V-151KB00AAA0	TNR7V151K	95	125		9			250	600	150 (135~165)	4.8
TND07V-181KB00AAA0	TNR7V181K	110	145		11			300	430	180 (162~198)	4.3
TND07V-201KB00AAA0	TNR7V201K	130	170		12.5			340	250	200 (185~225)	4.4
TND07V-221KB00AAA0	TNR7V221K	140	180	1,750A/1 time	13.5			360	230	220 (198~242)	4.5
TND07V-241KB00AAA0	TNR7V241K	150	200		15	0.25	10	395	210	240 (216~264)	4.6
TND07V-271KB00AAA0	TNR7V271K	175	225	1,250A/2 times	17			455	190	270 (247~303)	4.8
TND07V-331KB00AAA0	TNR7V331K	210	270		20			545	160	330 (297~363)	5.1
TND07V-361KB00AAA0	TNR7V361K	230	300		23			595	150	360 (324~396)	5.3
TND07V-391KB00AAA0	TNR7V391K	250	320		25			650	140	390 (351~429)	5.4
TND07V-431KB00AAA0	TNR7V431K	275	350		27.5			710	130	430 (387~473)	5.6
TND07V-471KB00AAA0	TNR7V471K	300	385		30			775	120	470 (423~517)	5.8
TND07V-511KB00AAA0	TNR7V511K	320	410		32			845	110	510 (459~561)	6.0

◆DIMENSIONS [mm]

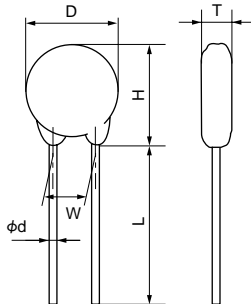

D Max.	H Max.	T Max.	L Min.	φd ±0.05	W ±1.0
8.5	11.5	Ref. to RATINGS	20.0	0.6	5.0



V Series

◆V-I CURVE (Type 7V)

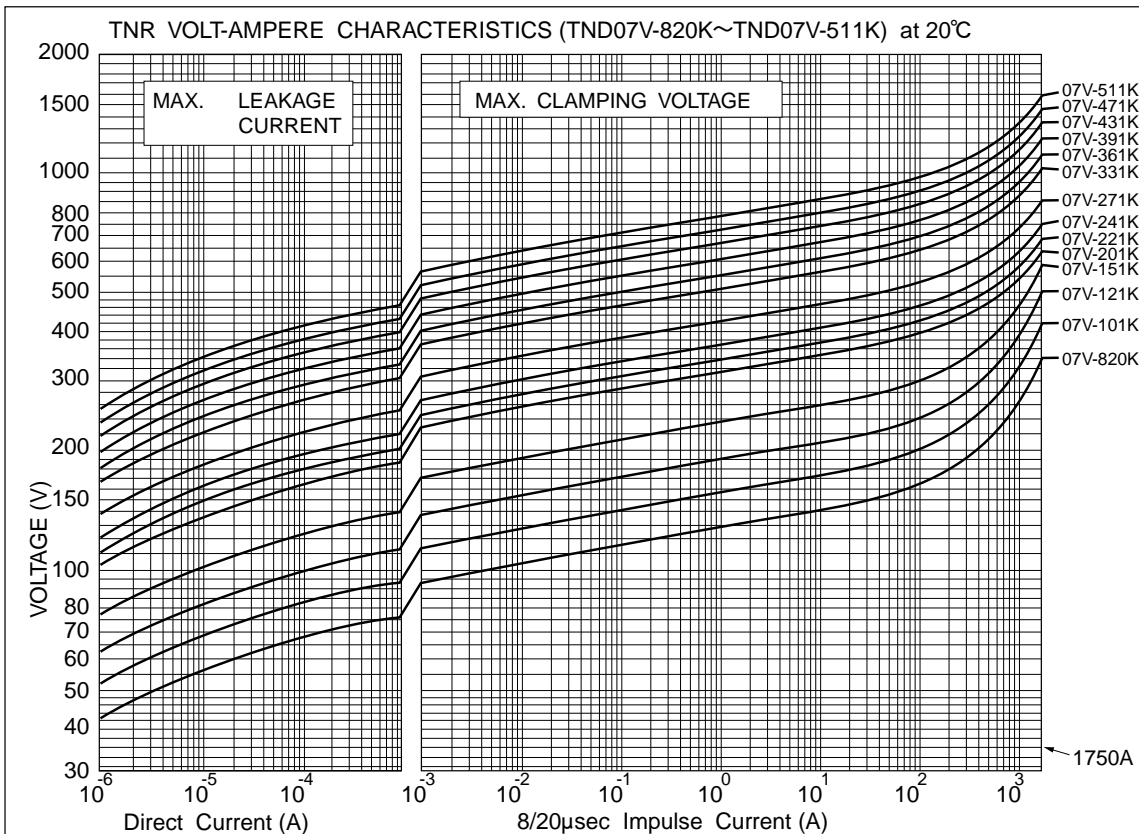
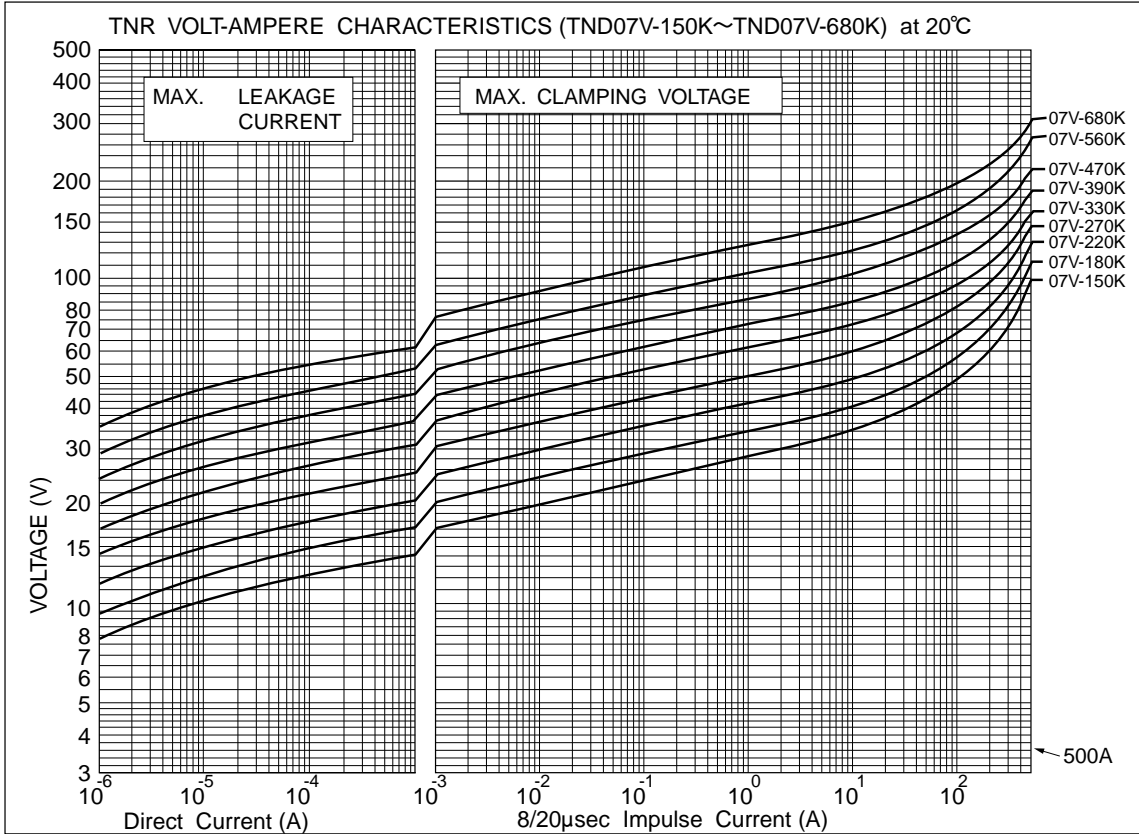

V Series

◆RATINGS (Type 9V)

Part Number	Previous Part Number (Just for your reference)	Maximum Ratings					Max. Clamping Voltage		Capacitance Typical @1kHz (pF)	Varistor Voltage V _{1mA} (V)	T Max. (mm)
		Max. Allowable Voltage		Max. Peak Current	Max. Energy	Rated Wattage	(A)	(V)			
		AC (Vrms)	DC (V)	8/20μs(A)	2ms(J)	(W)					
TND09V-150KB00AAA0	TNR9V150K	8	12	800A/1 time	2.0	0.02	5	30	9,600	15 (13~ 17)	3.8
TND09V-180KB00AAA0	TNR9V180K	11	14		2.2			36	8,000	18 (16~ 20)	3.8
TND09V-220KB00AAA0	TNR9V220K	14	18		2.6			43	7,000	22 (20~ 24)	4.0
TND09V-270KB00AAA0	TNR9V270K	17	22	400A/2 times	3.2	0.02	5	53	6,000	27 (24~ 30)	4.2
TND09V-330KB00AAA0	TNR9V330K	20	26		4.0			65	5,000	33 (30~ 36)	4.5
TND09V-390KB00AAA0	TNR9V390K	25	30		4.7			77	4,500	39 (35~ 43)	4.0
TND09V-470KB00AAA0	TNR9V470K	30	37	5.6	93	4,000	47 (42~ 52)	4.2			
TND09V-560KB00AAA0	TNR9V560K	35	44	6.7	110	3,500	56 (50~ 62)	4.4			
TND09V-680KB00AAA0	TNR9V680K	40	55	8.2	135	3,200	68 (61~ 75)	4.5			
TND09V-820KB00AAA0	TNR9V820K	50	65	10	135	1,700	82 (74~ 90)	3.8			
TND09V-101KB00AAA0	TNR9V101K	60	85	12	165	1,600	100 (90~110)	3.9			
TND09V-121KB00AAA0	TNR9V121K	75	100	14.5	200	1,400	120 (108~132)	4.1			
TND09V-151KB00AAA0	TNR9V151K	95	125	18	250	1,300	150 (135~165)	4.4			
TND09V-181KB00AAA0	TNR9V181K	110	145	22	300	900	180 (162~198)	4.0			
TND09V-201KB00AAA0	TNR9V201K	130	170	25	340	500	200 (185~225)	4.1			
TND09V-221KB00AAA0	TNR9V221K	140	180	3,000A/1 time	360	450	220 (198~242)	4.2			
TND09V-241KB00AAA0	TNR9V241K	150	200	2,000A/2 times	30	0.25	25	395	400	240 (216~264)	4.3
TND09V-271KB00AAA0	TNR9V271K	175	225		35			455	350	270 (247~303)	4.5
TND09V-331KB00AAA0	TNR9V331K	210	270		42			545	300	330 (297~363)	4.8
TND09V-361KB00AAA0	TNR9V361K	230	300	45	595	280	360 (324~396)	5.0			
TND09V-391KB00AAA0	TNR9V391K	250	320	50	650	260	390 (351~429)	5.1			
TND09V-431KB00AAA0	TNR9V431K	275	350	55	710	240	430 (387~473)	5.3			
TND09V-471KB00AAA0	TNR9V471K	300	385	60	775	220	470 (423~517)	5.6			
TND09V-511KB00AAA0	TNR9V511K	320	410	67	845	210	510 (459~561)	5.8			

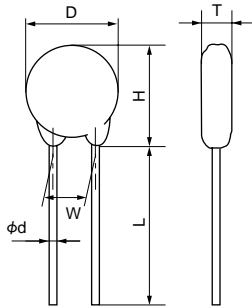
◆DIMENSIONS [mm]

D Max.	H Max.	T Max.	L Min.	φd ±0.05	W ±1.0
11.5	14.5	Ref. to RATINGS	20.0	0.6	5.0

V Series

◆V-I CURVE (Type 9V)

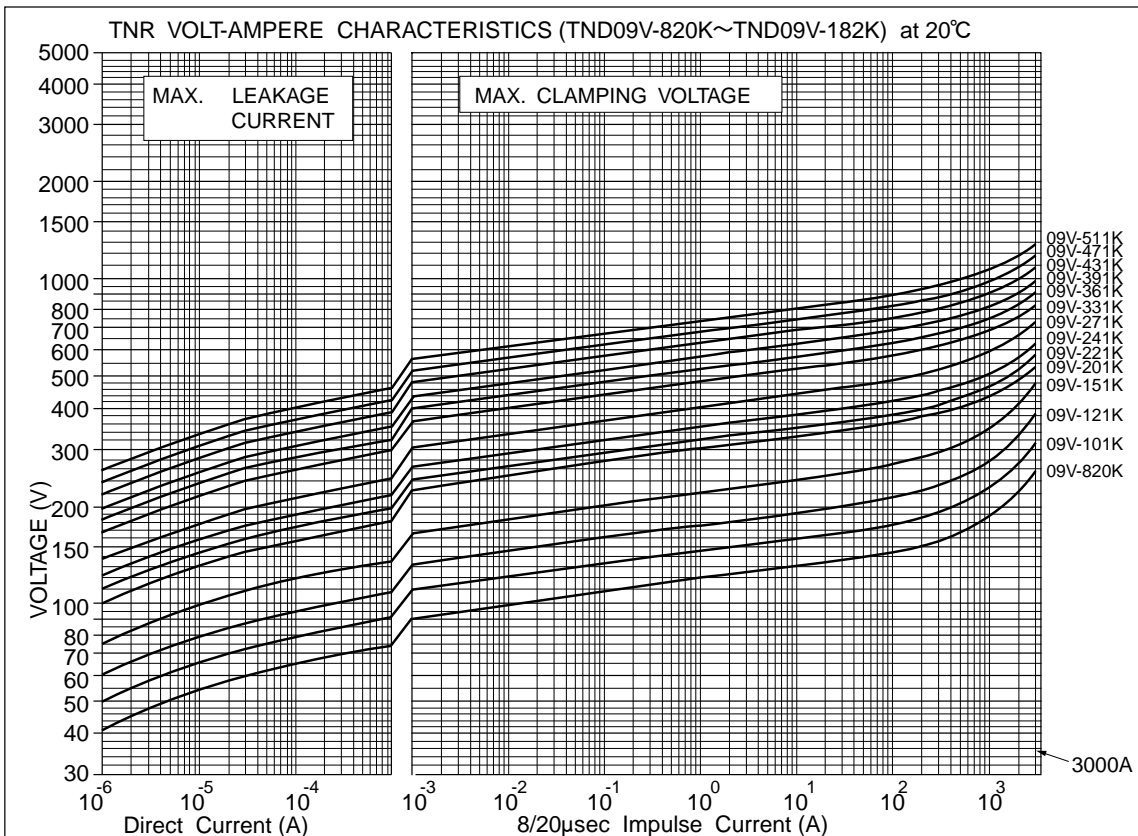
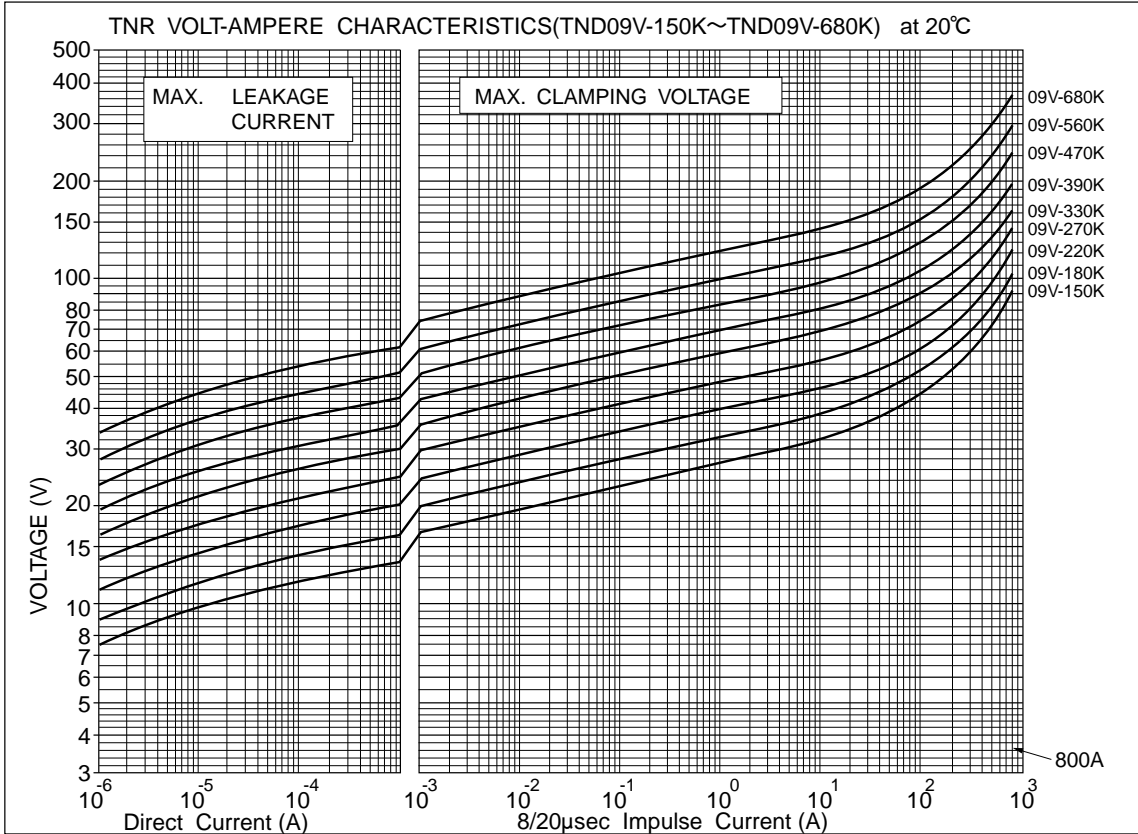

V Series

◆RATINGS (Type 10V)

Part Number	Previous Part Number (Just for your reference)	Maximum Ratings					Max. Clamping Voltage		Capacitance Typical @1kHz (pF)	Varistor Voltage V1mA (V)	E ±1.0 (mm)	T Max. (mm)
		Max. Allowable Voltage		Max. Peak Current	Max. Energy	Rated Wattage	(A)	(V)				
		AC (Vrms)	DC (V)	8/20µs(A)	2ms(J)	(W)						
TND10V-150KB00AAA0	TNR10V150K	8	12		2.0			30	9,600	15 (13~ 17)	1.2	4.5
TND10V-180KB00AAA0	TNR10V180K	11	14		2.2			36	8,000	18 (16~ 20)	1.3	4.6
TND10V-220KB00AAA0	TNR10V220K	14	18		2.6			43	7,000	22 (20~ 24)	1.4	4.7
TND10V-270KB00AAA0	TNR10V270K	17	22	1,000A/1 time	3.2			53	6,000	27 (24~ 30)	1.5	4.8
TND10V-330KB00AAA0	TNR10V330K	20	26		4.0	0.05	5	65	5,000	33 (30~ 36)	1.7	5.0
TND10V-390KB00AAA0	TNR10V390K	25	30	500A/2 times	4.7			77	4,500	39 (35~ 43)	1.6	4.9
TND10V-470KB00AAA0	TNR10V470K	30	37		5.6			93	4,000	47 (42~ 52)	1.7	5.0
TND10V-560KB00AAA0	TNR10V560K	35	44		6.7			110	3,500	56 (50~ 62)	1.8	5.1
TND10V-680KB00AAA0	TNR10V680K	40	55		8.2			135	3,200	68 (61~ 75)	2.0	5.3
TND10V-820KB00AAA0	TNR10V820K	50	65		10			135	1,700	82 (74~ 90)	1.6	4.5
TND10V-101KB00AAA0	TNR10V101K	60	85		12			165	1,600	100 (90~ 110)	1.8	4.7
TND10V-121KB00AAA0	TNR10V121K	75	100		14.5			200	1,400	120 (108~ 132)	2.0	4.9
TND10V-151KB00AAA0	TNR10V151K	95	125		18			250	1,300	150 (135~ 165)	2.3	5.2
TND10V-181KB00AAA0	TNR10V181K	110	145		22			300	900	180 (162~ 198)	1.8	4.7
TND10V-201KB00AAA0	TNR10V201K	130	170		25			340	500	200 (185~ 225)	1.9	4.8
TND10V-221KB00AAA0	TNR10V221K	140	180		27.5			360	450	220 (198~ 242)	2.0	4.9
TND10V-241KB00AAA0	TNR10V241K	150	200		30			395	400	240 (216~ 264)	2.1	5.0
TND10V-271KB00AAA0	TNR10V271K	175	225		35			455	350	270 (247~ 303)	2.3	5.2
TND10V-331KB00AAA0	TNR10V331K	210	270		42			545	300	330 (297~ 363)	2.6	5.5
TND10V-361KB00AAA0	TNR10V361K	230	300		45			595	280	360 (324~ 396)	2.8	5.7
TND10V-391KB00AAA0	TNR10V391K	250	320	3,500A/1 time	50			650	260	390 (351~ 429)	2.9	5.8
TND10V-431KB00AAA0	TNR10V431K	275	350		55	0.4	25	710	240	430 (387~ 473)	3.1	6.0
TND10V-471KB00AAA0	TNR10V471K	300	385	2,500A/2 times	60			775	220	470 (423~ 517)	3.3	6.2
TND10V-511KB00AAA0	TNR10V511K	320	410		67			845	210	510 (459~ 561)	3.5	6.4
TND10V-561KB00AAA0	TNR10V561K	350	460		67			922	195	560 (504~ 616)	3.8	6.7
TND10V-621KB00AAA0	TNR10V621K	385	505		67			1,025	180	620 (558~ 682)	4.2	7.1
TND10V-681KB00AAA0	TNR10V681K	420	560		67			1,120	165	680 (612~ 748)	4.5	7.4
TND10V-751KB00AAA0	TNR10V751K	460	615		70			1,240	150	750 (675~ 825)	4.9	7.8
TND10V-821KB00AAA0	TNR10V821K	510	670		80			1,355	140	820 (738~ 902)	5.2	8.1
TND10V-911KB00AAA0	TNR10V911K	550	745		90			1,500	125	910 (819~1,001)	5.7	8.6
TND10V-102KB00AAA0	TNR10V102K	625	825		100			1,650	115	1,000 (900~1,100)	6.2	9.1
TND10V-112KB00AAA0	TNR10V112K	680	895		110			1,815	105	1,100 (990~1,210)	6.8	9.7
TND10V-122KB00AAA0	TNR10V122K	720	980		120			1,950	95	1,200 (1,080~1,320)	7.1	10.5
TND10V-152KB00AAA0	TNR10V152K	860	1,220		150			2,440	85	1,500 (1,350~1,650)	8.7	12.4
TND10V-182KB00AAA0	TNR10V182K	1,000	1,465		183			2,970	70	1,800 (1,700~1,980)	10.5*	14.4

*E±2.0

◆DIMENSIONS [mm]

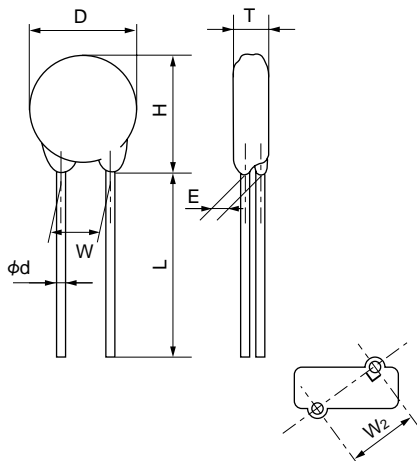

Part Number	D Max.	H Max.	T Max.	L Min.	φd ±0.05	W ±1.0
TND10V-150K to TND10V-511K	11.5	14.5	Ref. to RATINGS	20.0	0.8	7.5
TND10V-561K to TND10V-112K	12.5	15.5				11.0*
TND10V-122K to TND10V-182K	13.5	16.5				

*W2±2.0



V Series

◆V-I CURVE (Type 10V)

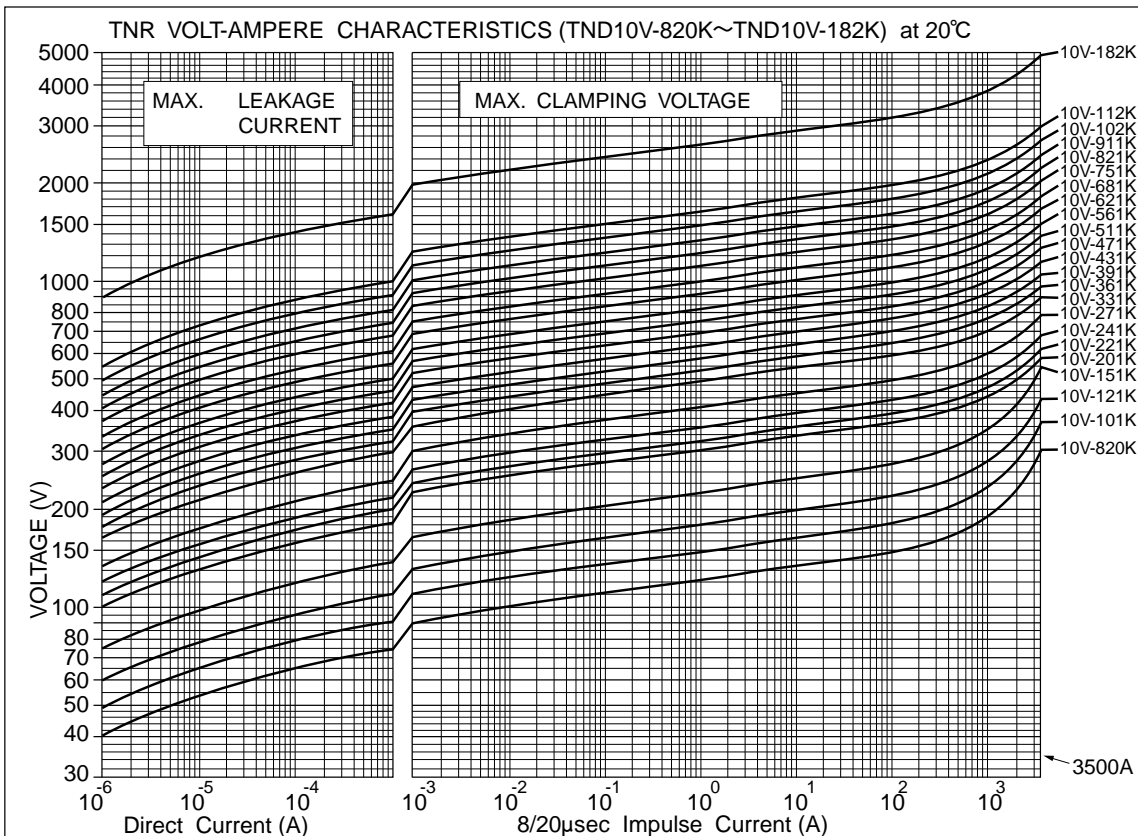
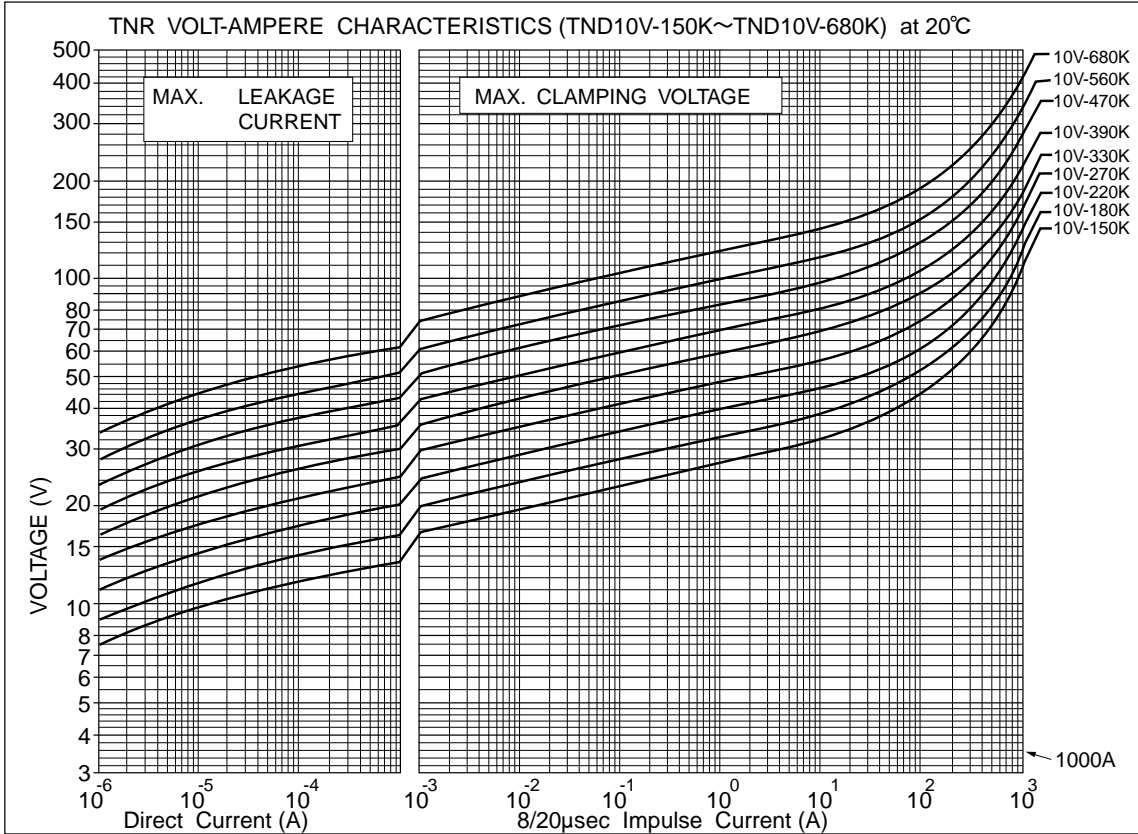

V Series

◆RATINGS (Type 14V)

Part Number	Previous Part Number (Just for your reference)	Maximum Ratings					Max. Clamping Voltage		Capacitance Typical @1kHz (pF)	Varistor Voltage V _{1mA} (V)	E ±1.0 (mm)	T Max. (mm)
		Max. Allowable Voltage		Max. Peak Current	Max. Energy	Rated Wattage	(A)	(V)				
		AC (Vrms)	DC (V)	8/20μs(A)	2ms(J)	(W)						
TND14V-150KB00AAA0	TNR14V150K	8	12		3.6			30	19,500	15 (13~ 17)	1.2	4.5
TND14V-180KB00AAA0	TNR14V180K	11	14		4.3			36	16,500	18 (16~ 20)	1.3	4.6
TND14V-220KB00AAA0	TNR14V220K	14	18		5.3			43	13,500	22 (20~ 24)	1.4	4.7
TND14V-270KB00AAA0	TNR14V270K	17	22	2,000A/1 time	6.5			53	12,000	27 (24~ 30)	1.5	4.8
TND14V-330KB00AAA0	TNR14V330K	20	26		7.9	0.1	10	65	10,000	33 (30~ 36)	1.7	5.0
TND14V-390KB00AAA0	TNR14V390K	25	30	1,000A/2 times	9.4			77	9,000	39 (35~ 43)	1.6	4.9
TND14V-470KB00AAA0	TNR14V470K	30	37		11			93	8,000	47 (42~ 52)	1.7	5.0
TND14V-560KB00AAA0	TNR14V560K	35	44		13			110	7,500	56 (50~ 62)	1.8	5.1
TND14V-680KB00AAA0	TNR14V680K	40	55		16			135	6,500	68 (61~ 75)	2.0	5.3
TND14V-820KB00AAA0	TNR14V820K	50	65		20			135	3,000	82 (74~ 90)	1.6	4.5
TND14V-101KB00AAA0	TNR14V101K	60	85		25			165	2,700	100 (90~ 110)	1.8	4.7
TND14V-121KB00AAA0	TNR14V121K	75	100		30			200	2,500	120 (108~ 132)	2.0	4.9
TND14V-151KB00AAA0	TNR14V151K	95	125		37			250	2,300	150 (135~ 165)	2.3	5.2
TND14V-181KB00AAA0	TNR14V181K	110	145		45			300	1,650	180 (162~ 198)	1.8	4.7
TND14V-201KB00AAA0	TNR14V201K	130	170		50			340	950	200 (185~ 225)	1.9	4.8
TND14V-221KB00AAA0	TNR14V221K	140	180	6,000A/1 time	55			360	850	220 (198~ 242)	2.0	4.9
TND14V-241KB00AAA0	TNR14V241K	150	200		60			395	800	240 (216~ 264)	2.1	5.0
TND14V-271KB00AAA0	TNR14V271K	175	225	5,000A/2 times	70			455	700	270 (247~ 303)	2.3	5.2
TND14V-331KB00AAA0	TNR14V331K	210	270		80			545	600	330 (297~ 363)	2.6	5.5
TND14V-361KB00AAA0	TNR14V361K	230	300		90			595	550	360 (324~ 396)	2.8	5.7
TND14V-391KB00AAA0	TNR14V391K	250	320		100			650	500	390 (351~ 429)	2.9	5.8
TND14V-431KB00AAA0	TNR14V431K	275	350		110	0.6	50	710	460	430 (387~ 473)	3.1	6.0
TND14V-471KB00AAA0	TNR14V471K	300	385		125			775	420	470 (423~ 517)	3.3	6.2
TND14V-511KB00AAA0	TNR14V511K	320	410		136			845	390	510 (459~ 561)	3.5	6.4
TND14V-561KB00AAA0	TNR14V561K	350	460		136			922	360	560 (504~ 616)	3.8	6.7
TND14V-621KB00AAA0	TNR14V621K	385	505		136			1,025	330	620 (558~ 682)	4.2	7.1
TND14V-681KB00AAA0	TNR14V681K	420	560		136			1,120	310	680 (612~ 748)	4.5	7.4
TND14V-751KB00AAA0	TNR14V751K	460	615		150			1,240	280	750 (675~ 825)	4.9	7.8
TND14V-821KB00AAA0	TNR14V821K	510	670	5,000A/1 time	165			1,355	250	820 (738~ 902)	5.2	8.1
TND14V-911KB00AAA0	TNR14V911K	550	745		180			1,500	230	910 (819~1,001)	5.7	8.6
TND14V-102KB00AAA0	TNR14V102K	625	825	4,500A/2 times	200			1,650	210	1,000 (900~1,100)	6.2	9.1
TND14V-112KB00AAA0	TNR14V112K	680	895		220			1,815	190	1,100 (990~1,210)	6.8	9.7
TND14V-122KB00AAA0	TNR14V122K	720	980		240			1,950	170	1,200 (1,080~1,320)	7.1	10.5
TND14V-152KB00AAA0	TNR14V152K	860	1,220		300			2,440	150	1,500 (1,350~1,650)	8.7	12.4
TND14V-182KB00AAA0	TNR14V182K	1,000	1,465		360			2,970	120	1,800 (1,700~1,980)	10.5*	14.4

*E±2.0

◆DIMENSIONS [mm]

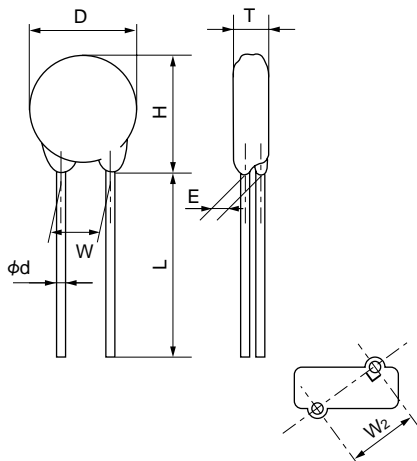

Part Number	D Max.	H Max.	T Max.	L Min.	φd ±0.05	W ±1.0
TND14V-150K to TND14V-511K	15.5	18.5	Ref. to RATINGS	20	0.8	7.5
TND14V-561K to TND14V-112K	16.0	19.0				
TND14V-122K to TND14V-182K	17.0	20.5				

*W±2.0

V Series

◆V-I CURVE (Type 14V)

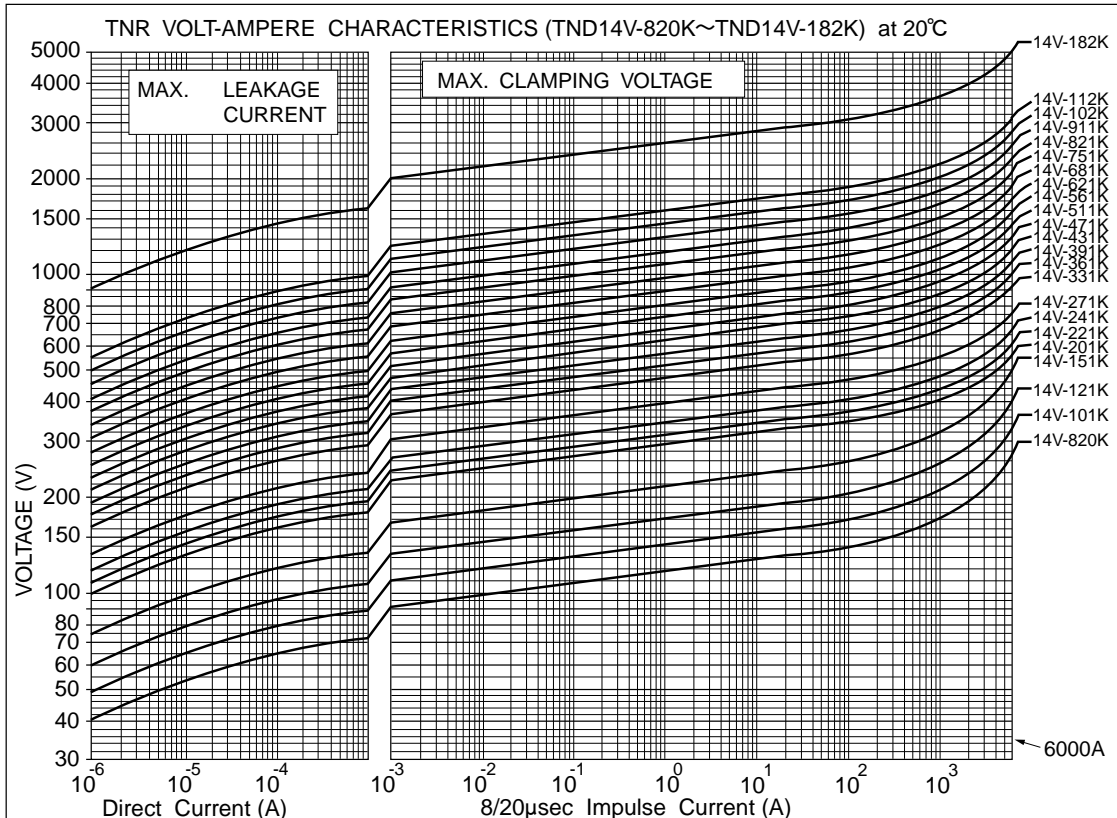
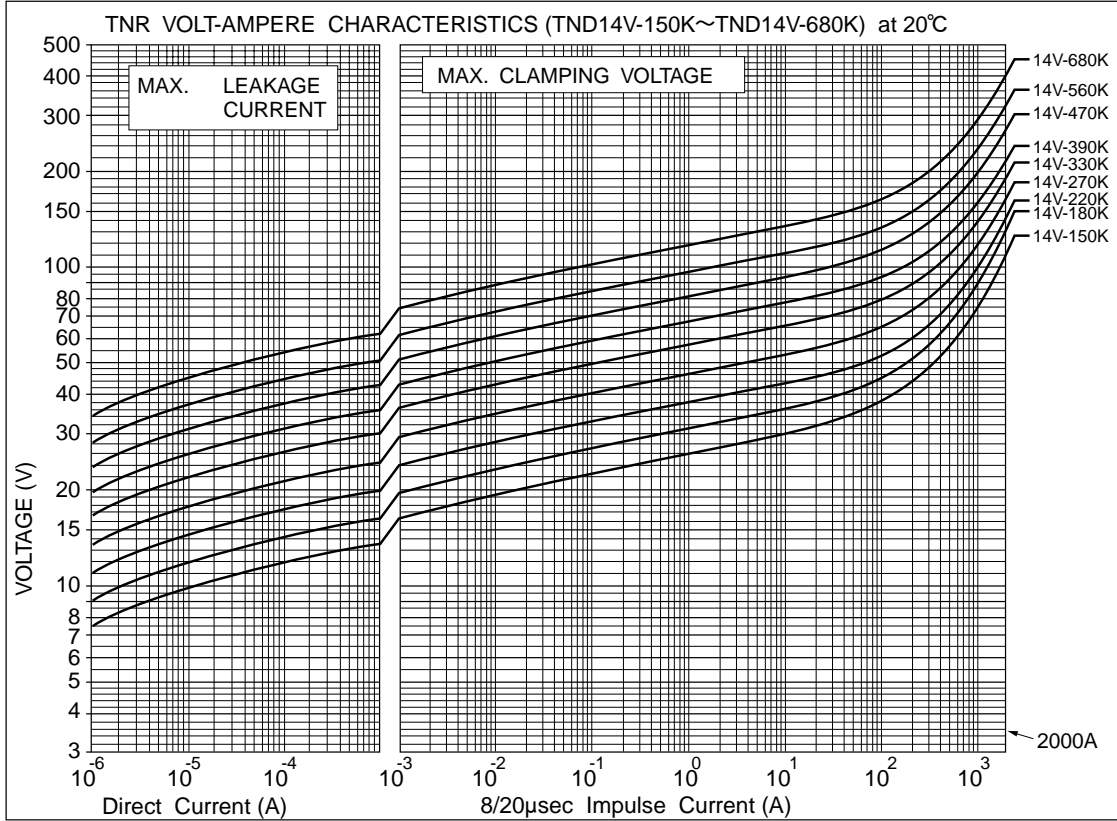

V Series

◆RATINGS (Type 20V)

Part Number	Previous Part Number (Just for your reference)	Maximum Ratings					Max. Clamping Voltage		Capacitance Typical @1kHz (pF)	Varistor Voltage V1mA (V)	E ±1.0 (mm)	T Max. (mm)
		Max. Allowable Voltage		Max. Peak Current	Max. Energy	Rated Wattage	(A)	(V)				
		AC (Vrms)	DC (V)	8/20µs(A)	2ms(J)	(W)						
TND20V-180KB00AAA0	TNR20V180K	11	14		12			36	39,000	18 (16~ 20)	1.5	5.1
TND20V-220KB00AAA0	TNR20V220K	14	18		14			43	33,000	22 (20~ 24)	1.6	5.2
TND20V-270KB00AAA0	TNR20V270K	17	22	3,000A/1 time	17			53	28,000	27 (24~ 30)	1.7	5.3
TND20V-330KB00AAA0	TNR20V330K	20	26		21	0.2	20	65	24,000	33 (30~ 36)	1.9	5.5
TND20V-390KB00AAA0	TNR20V390K	25	30	2,000A/2 times	25			77	21,000	39 (35~ 43)	1.9	5.5
TND20V-470KB00AAA0	TNR20V470K	30	37		30			93	19,000	47 (42~ 52)	2.0	5.6
TND20V-560KB00AAA0	TNR20V560K	35	44		36			110	17,000	56 (50~ 62)	2.1	5.7
TND20V-680KB00AAA0	TNR20V680K	40	55		44			135	15,000	68 (61~ 75)	2.2	5.8
TND20V-820KB00AAA0	TNR20V820K	50	65		40			135	6,700	82 (74~ 90)	1.8	4.9
TND20V-101KB00AAA0	TNR20V101K	60	85		50			165	6,100	100 (90~ 110)	2.0	5.1
TND20V-121KB00AAA0	TNR20V121K	75	100		60			200	5,600	120 (108~ 132)	2.2	5.3
TND20V-151KB00AAA0	TNR20V151K	95	125		75			250	5,100	150 (135~ 165)	2.5	5.6
TND20V-181KB00AAA0	TNR20V181K	110	145		85			300	3,900	180 (162~ 198)	2.0	5.1
TND20V-201KB00AAA0	TNR20V201K	130	170		100			340	2,700	200 (185~ 225)	2.1	5.2
TND20V-221KB00AAA0	TNR20V221K	140	180	10,000A/1 time	110			360	2,500	220 (198~ 242)	2.2	5.3
TND20V-241KB00AAA0	TNR20V241K	150	200		120			395	2,300	240 (216~ 264)	2.3	5.4
TND20V-271KB00AAA0	TNR20V271K	175	225	7,000A/2 times	135			455	2,000	270 (247~ 303)	2.5	5.6
TND20V-331KB00AAA0	TNR20V331K	210	270		160			545	1,700	330 (297~ 363)	2.8	5.9
TND20V-361KB00AAA0	TNR20V361K	230	300		180			595	1,500	360 (324~ 396)	3.0	6.1
TND20V-391KB00AAA0	TNR20V391K	250	320		195			650	1,400	390 (351~ 429)	3.1	6.2
TND20V-431KB00AAA0	TNR20V431K	275	350		215	1.0	100	710	1,300	430 (387~ 473)	3.3	6.4
TND20V-471KB00AAA0	TNR20V471K	300	385		250			775	1,200	470 (423~ 517)	3.5	6.6
TND20V-511KB00AAA0	TNR20V511K	320	410		273			845	1,100	510 (459~ 561)	3.7	6.8
TND20V-561KB00AAA0	TNR20V561K	350	460		273			922	1,000	560 (504~ 616)	4.0	7.1
TND20V-621KB00AAA0	TNR20V621K	385	505		273			1,025	900	620 (558~ 682)	4.4	7.5
TND20V-681KB00AAA0	TNR20V681K	420	560		273			1,120	830	680 (612~ 748)	4.7	7.8
TND20V-751KB00AAA0	TNR20V751K	460	615		300			1,240	750	750 (675~ 825)	5.1	8.2
TND20V-821KB00AAA0	TNR20V821K	510	670	7,500A/1 time	325			1,355	700	820 (738~ 902)	5.4	8.5
TND20V-911KB00AAA0	TNR20V911K	550	745		360			1,500	620	910 (819~1,001)	5.9	9.0
TND20V-102KB00AAA0	TNR20V102K	625	825	6,500A/2 times	400			1,650	560	1,000 (900~1,100)	6.4	9.5
TND20V-112KB00AAA0	TNR20V112K	680	895		440			1,815	510	1,100 (990~1,210)	7.0	10.1
TND20V-122KB00AAA0	TNR20V122K	720	980		480			1,950	450	1,200 (1,080~1,320)	7.3	10.8
TND20V-152KB00AAA0	TNR20V152K	860	1,220		600			2,440	390	1,500 (1,350~1,650)	8.9	12.8
TND20V-182KB00AAA0	TNR20V182K	1,000	1,465		720			2,970	340	1,800 (1,700~1,980)	10.7*	14.8

*E±2.0

◆DIMENSIONS [mm]

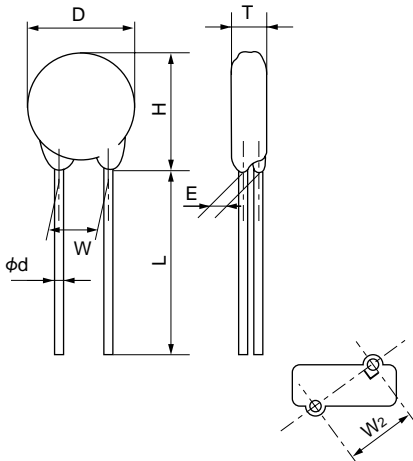

Part Number	D Max.	H Max.	T Max.	L Min.	φd ±0.05	W ±1.0
TND20V-180K to TND20V-511K	21.5	24.5	Ref. to Ratings	20	0.8	10.0
TND20V-561K to TND20V-112K	22.5	25.5				
TND20V-122K	23.5	28.0	10.8			13.0*
TND20V-152K			12.8			
TND20V-182K			14.8			

*W2±2.0



V Series

◆V-I CURVE (Type 20V)

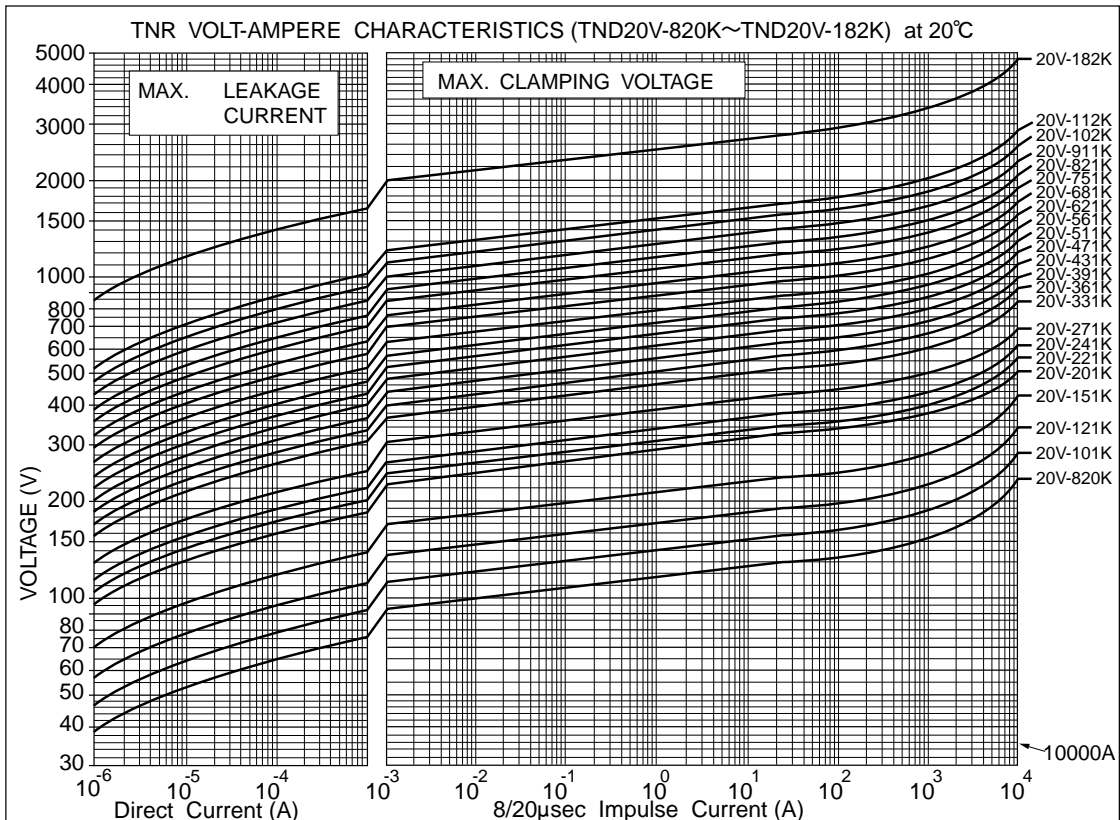
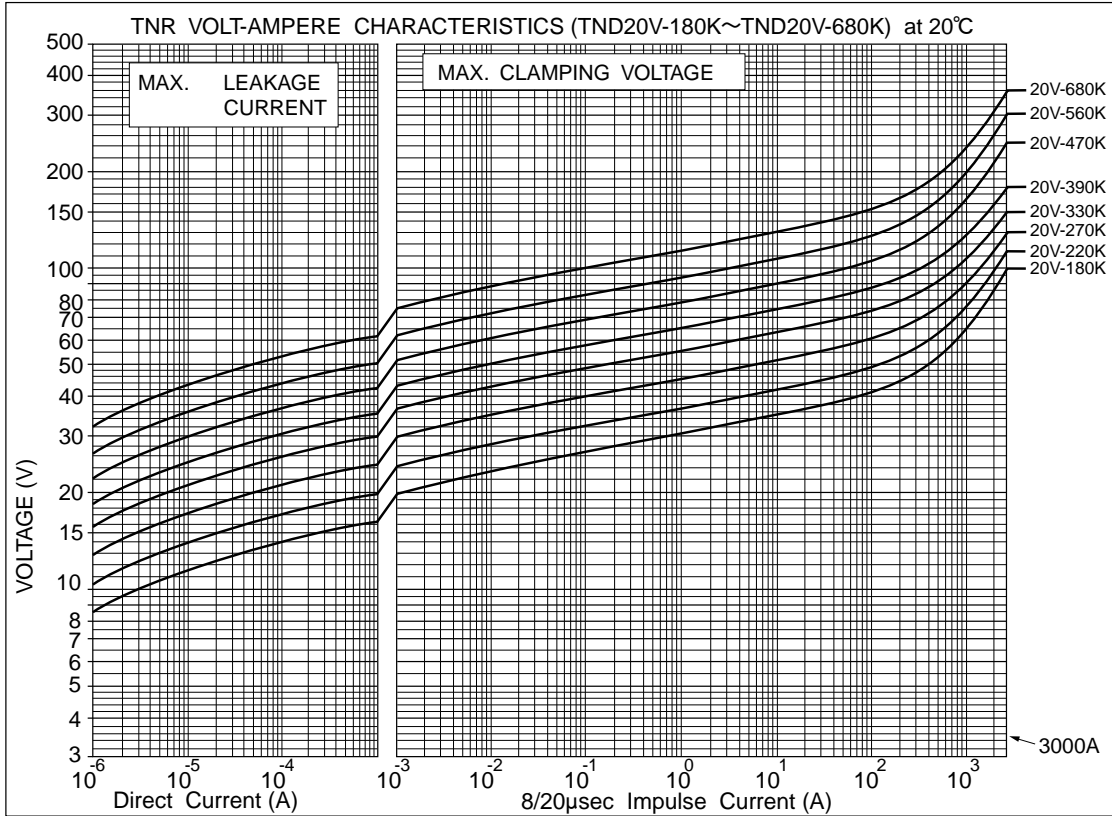

◆GENERAL SPECIFICATIONS

Item	Test Conditions	Specifications						
Standard Test Condition	20±5°C, 65±20% RH unless specified. However, if it does not affect test result, the condition can be 20±15°C, 65±20% RH also.							
Varistor Voltage	Voltage across varistor at specified current. <table border="1" style="margin-left: 20px;"> <thead> <tr> <th>Type</th> <th>Current C(mA)</th> </tr> </thead> <tbody> <tr> <td>5V</td> <td>0.1</td> </tr> <tr> <td>7V, 9V, 10V, 14V, 20V</td> <td>1.0</td> </tr> </tbody> </table>	Type	Current C(mA)	5V	0.1	7V, 9V, 10V, 14V, 20V	1.0	Satisfy the specification
Type	Current C(mA)							
5V	0.1							
7V, 9V, 10V, 14V, 20V	1.0							
Maximum Allowable Voltage	Maximum continuous AC voltage (50~60Hz AC) and maximum DC voltage which can be applied.	Satisfy the specification						
Maximum Peak Surge Current	Maximum surge current (8/20µsec. pulse wave to be applied once, or twice, 2 minute apart) for varistor voltage change within ±10% of the initial value.	Satisfy the specification						
Energy Rating	Maximum energy (2msec. square wave to be applied once) for varistor voltage change within ±10% of the initial value.	Satisfy the specification						
Rated Wattage	Maximum power (50~60Hz AC power to be applied for 1,000 hours at 85±2°C) for varistor voltage change within ±10% of the initial value.	Satisfy the specification						
Maximum Clamping Voltage	Maximum voltage across varistor when 8/20µSec. rated current surge is applied.	Satisfy the specification						
Capacitance	Varistor's capacitance at 1kHz, standard test condition.	For reference only.						
Voltage Temperature Coefficient	$\frac{V_{cmA} \text{ at } 85^{\circ}\text{C} - V_{cmA} \text{ at } 25^{\circ}\text{C}}{V_{cmA} \text{ at } 25^{\circ}\text{C}} \times \frac{1}{60} \times 100 (\% / ^{\circ}\text{C})$ VcmA : Actual varistor voltage	Within ±0.05%/°C						
Insulation	Short circuit the two leads of varistor, and put the varistor body into lead balls (1.6mm diameter) leaving 2mm epoxy coating outside. Then, apply 2.5kVrms between the leads and the lead balls for 60±5 seconds.	The varistor shall withstand with no abnormality.						

◆RELIABILITY CHARACTERISTICS

Item	Test Conditions	Specifications
Heat Cycle	Subject varistor to the following temperature cycles. -40°C for 30 minutes → Normal room temperature for 10 minutes → 85°C for 30 minutes → Normal room temperature for 10 minutes. This completes one cycle. The cycle shall be repeated 5 times total. After the cycles, the varistor shall be stored at normal room temperature for one hour. Then check the varistor voltage and the appearance.	$\Delta V_{cmA} \leq \pm 5\%$ No appearance abnormality.
High Temperature Exposure	Store varistor at 125°C for 1,000 hours. After that, store the varistor at normal room temperature for one hour. Then check the varistor voltage.	$\Delta V_{cmA} \leq \pm 5\%$ However, on varistors have nominal varistor voltages from 15V to 68V, the varistor voltage change shall be $\Delta V_{cmA} \leq \pm 10\%$
Humidity Resistivity	Store at 40°C, 90 to 95% RH for 1,000 hours. After that, store the varistor at normal room temperature for one hour. Then check the varistor voltage.	$\Delta V_{cmA} \leq \pm 5\%$
High Temperature Operation	Apply maximum applied voltage to varistor at 85°C for 1,000 hours. After that, store the varistor at normal room temperature for one hour. Then check the varistor voltage.	$\Delta V_{cmA} \leq \pm 10\%$

◆MECHANICAL CHARACTERISTICS

Item	Test Conditions	Specifications									
Soldering Heat Resistivity	Store varistor at normal room temperature. Dip the varistor leads to solder, at 350±10°C for 3 ± 0 seconds, up to 2.0~2.5 mm from the varistor body. After that, store the varistor at normal room temperature for 30 minutes, and measure the varistor voltage.	$\Delta V_{cmA} \leq \pm 5\%$ Vc : Actual varistor voltage No mechanical damages									
Solderability	Dip varistor leads to methanol solution (JIS K 1501, about 25%) of rosin (JIS Z 5902) for 5~10 seconds. Then, dip the lead to solder (JIS Z 3282 H60A or H63A) at 225~240°C, up to 2.0~2.5mm from the varistor body for 5±0.5 seconds. Then, check the solderability.	At least, 95% of the surface dipped to solder shall be covered by new solder.									
Lead Pull Strength	Fix varistor body, and suspend specified weight toward direction of lead axis.	No abnormality such as disconnection. $\Delta V_{cmA} \leq \pm 5\%$									
	<table border="1"> <thead> <tr> <th>Type</th> <th>Lead Diameter</th> <th>Weight</th> </tr> </thead> <tbody> <tr> <td>5V, 7V, 9V</td> <td>0.6mm</td> <td>10N</td> </tr> <tr> <td>10V, 14V, 20V</td> <td>0.8mm</td> <td>10N</td> </tr> </tbody> </table>		Type	Lead Diameter	Weight	5V, 7V, 9V	0.6mm	10N	10V, 14V, 20V	0.8mm	10N
	Type		Lead Diameter	Weight							
5V, 7V, 9V	0.6mm	10N									
10V, 14V, 20V	0.8mm	10N									
Lead Bend Strength	Fix varistor body vertically. Then suspend specified weight and bent the varistor body by 90°, and return it to the original position. Carry out the operation in the opposite direction and return the body to the original position.	The leads shall not disconnect, slacken and peel off.									
	<table border="1"> <thead> <tr> <th>Type</th> <th>Lead Diameter</th> <th>Weight</th> </tr> </thead> <tbody> <tr> <td>5V, 7V, 9V</td> <td>0.6mm</td> <td>5N</td> </tr> <tr> <td>10V, 14V, 20V</td> <td>0.8mm</td> <td>5N</td> </tr> </tbody> </table>		Type	Lead Diameter	Weight	5V, 7V, 9V	0.6mm	5N	10V, 14V, 20V	0.8mm	5N
	Type		Lead Diameter	Weight							
5V, 7V, 9V	0.6mm	5N									
10V, 14V, 20V	0.8mm	5N									
Vibration Resistivity	Mount varistor body on vibrator, and conduct following vibration test. Peak-to-Peak amplitude : 1.5mm Vibration frequency range : 10Hz to 55Hz Sweeping time: Approximately one minute for 10Hz → 55Hz → 10Hz Direction and duration of vibration : Three directions of X, Y and Z. Two hours each. Six hours total.	No remarkable appearance abnormality. $\Delta V_{cmA} \pm 5\%$									



SE Series

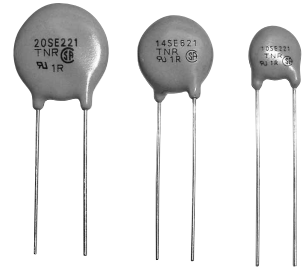

When the surge energy much higher than the rated maximum energy is applied to the varistors, it may blow up and catch fire.
 Our newly developed TNR SE series is to prevent from being caught fire even very high surge energy is applied.
 Thus electric appliance using our TNR SE series can be much safer.

◆FEATURES

- Newly developed non-flammable material (Halogen Free) is used for outer coating.
- The new outer coating will meet UL flammability test.
- At the over voltage test, the new material shall deter burning caused by the high temperature, arc and the large surge current when TNR shall blow up.
- General specifications are same as that of V series, large surge capability TNR.

◆APPLICATIONS

- Protection for semiconductors from over voltage.
- Protection for electronic instruments from lightning surge.
- Absorption of on-off surge from motors and relays.

Operating Temperature Range: -40 to +85°C
 Storage Temperature Range: -50 to +125°C

◆PART NUMBERING SYSTEM

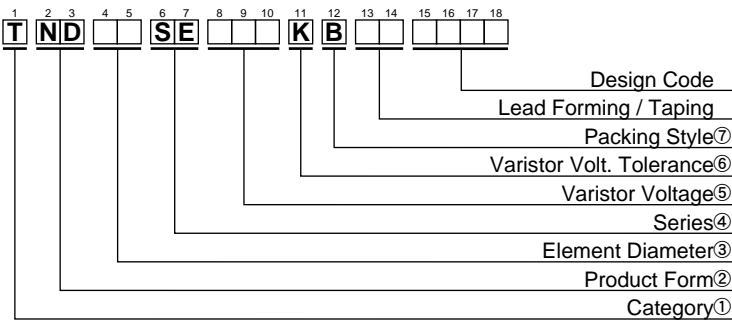

①Category	
T	Metal Oxide Varistors TNR

②Product Form	
ND	DISK Type

③Element Diameter	
10	φ10mm
14	φ14mm
20	φ20mm

④Series	
SE	SE Series

⑤Varistor Voltage
The first two digits are significant figures and the third one denotes the number of following zeros.

⑥Varistor Volt. Tolerance	
K	±10%

⑦Packing Style	
B	Bulk
T	Taping

- UL recognized
 UL1449 : File E95427
 UL1414 : File E65426
- CSA recognized
 CSA CLASS 2221 01 : File LR 97864
- VDE recognized
 CECC 42000, CECC 42200, CECC 42201 : File 118623

◆ RATINGS AND CHARACTERISTICS

Part Number	Previous Part Number (Just for your reference)	Maximum Ratings				Max. Clamping Voltage		Capacitance Typical @1kHz (pF)	Varistor Voltage V _{1mA} (V)	
		Max. Allowable Voltage		Max. Peak Current	Max. Energy	Rated Wattage	(A)			(V)
		AC (Vrms)	DC (V)	8/20μs(A)	2ms(J)	(W)				
TND10SE221KB00AAA0	TNR10SE221K	140	180	3,500A/1 time	27.5	0.4	25	360	450	220 (198~242)
TND10SE241KB00AAA0	TNR10SE241K	150	200		30			395	400	240 (216~264)
TND10SE271KB00AAA0	TNR10SE271K	175	225	2,500A/2 times	35	0.4	25	455	350	270 (247~303)
TND10SE431KB00AAA0	TNR10SE431K	275	350		55			710	240	430 (387~473)
TND10SE471KB00AAA0	TNR10SE471K	300	385	60	775	220	470 (423~517)			
TND10SE511KB00AAA0	TNR10SE511K	320	410	67	845	210	510 (459~561)			
TND10SE621KB00AAA0	TNR10SE621K	385	505	67	1,025	180	620 (558~682)			
TND14SE221KB00AAA0	TNR14SE221K	140	180	6,000A/1 time	55	0.6	50	360	850	220 (198~242)
TND14SE241KB00AAA0	TNR14SE241K	150	200		60			395	800	240 (216~264)
TND14SE271KB00AAA0	TNR14SE271K	175	225	5,000A/2 times	70	0.6	50	455	700	270 (247~303)
TND14SE431KB00AAA0	TNR14SE431K	275	350		110			710	460	430 (387~473)
TND14SE471KB00AAA0	TNR14SE471K	300	385	125	775	420	470 (423~517)			
TND14SE511KB00AAA0	TNR14SE511K	320	410	136	845	390	510 (459~561)			
TND14SE621KB00AAA0	TNR14SE621K	385	505	5,000A/1 time 4,500A/2 times	136			1,025	330	620 (558~682)
TND20SE221KB00AAA0	TNR20SE221K	140	180	10,000A/1 time	110	1.0	100	360	2,500	220 (198~242)
TND20SE241KB00AAA0	TNR20SE241K	150	200		120			395	2,300	240 (216~264)
TND20SE271KB00AAA0	TNR20SE271K	175	225	7,000A/2 times	135	1.0	100	455	2,000	270 (247~303)
TND20SE431KB00AAA0	TNR20SE431K	275	350		215			710	1,300	430 (387~473)
TND20SE471KB00AAA0	TNR20SE471K	300	385	250	775	1,200	470 (423~517)			
TND20SE511KB00AAA0	TNR20SE511K	320	410	273	845	1,100	510 (459~561)			
TND20SE621KB00AAA0	TNR20SE621K	385	505	7,500A/1 time 6,500A/2 times	273			1,025	900	620 (558~682)

◆ DIMENSIONS [mm]

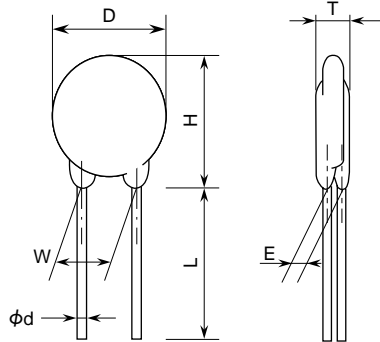

Part Number	D Max.	H Max.	T Max.	L Min.	φd ±0.05	W ±1.0	E ±1.0
TND10SE221K	13.0	17.5	6.9	20	0.8	7.5	2.0
TND10SE241K			2.1				
TND10SE271K			2.3				
TND10SE431K	14.0	18.5	8.2	20	0.8	7.5	3.1
TND10SE471K			3.3				
TND10SE511K			3.5				
TND10SE621K	4.2						
TND14SE221K	17.5	22.0	6.9	20	0.8	7.5	2.0
TND14SE241K			2.1				
TND14SE271K			2.3				
TND14SE431K	18.5	24.0	8.2	20	0.8	7.5	3.1
TND14SE471K			3.3				
TND14SE511K			3.5				
TND14SE621K	4.2						
TND20SE221K	22.5	27.5	7.4	20	0.8	10.0	2.2
TND20SE241K			2.3				
TND20SE271K			2.5				
TND20SE431K	24.5	29.5	8.7	20	0.8	10.0	3.3
TND20SE471K			3.5				
TND20SE511K			3.7				
TND20SE621K	4.4						





SE Series

◆V-I CURVE

V-I characteristics is same as that of V series.

Please see V-I Curve of V series.

CROSS REFERENCE TABLE

TNR SE SERIES	TNR V SERIES	GO TO REF. PAGE
TND10SE221K TND10SE241K TND10SE271K TND10SE431K TND10SE471K TND10SE511K TND10SE621K	TND10V-221K TND10V-241K TND10V-271K TND10V-431K TND10V-471K TND10V-511K TND10V-621K	
TND14SE221K TND14SE241K TND14SE271K TND14SE431K TND14SE471K TND14SE511K TND14SE621K	TND14V-221K TND14V-241K TND14V-271K TND14V-431K TND14V-471K TND14V-511K TND14V-621K	
TND20SE221K TND20SE241K TND20SE271K TND20SE431K TND20SE471K TND20SE511K TND20SE621K	TND20V-221K TND20V-241K TND20V-271K TND20V-431K TND20V-471K TND20V-511K TND20V-621K	



SE Series

◆GENERAL SPECIFICATIONS

Operating Temperature Range: -40 to +85°C
Storage Temperature Range: -50 to +125°C

Item	Test Conditions	Specifications
Standard Test Condition	20±5°C, 65±20% RH unless specified. However, if it does not affect test result, the condition can be 20±15°C, 65±20% RH also.	
Varistor Voltage	The voltage between the two terminals measured at 1mA DC is called Varistor Voltage. The measurement shall be made as fast as possible to avoid heat effect.	Satisfy the specification
Maximum Allowable Voltage	Maximum continuous AC voltage (50 to 60Hz AC) and maximum DC voltage which can be applied.	Satisfy the specification
Maximum Peak Surge Current	Maximum surge current (8/20µsec. pulse wave to be applied once, or twice, 2 minute apart) for varistor voltage change within ±10% of the initial value.	Satisfy the specification
Energy Rating	Maximum energy (2msec. square wave to be applied once) for varistor voltage change within ±10% of the initial value.	Satisfy the specification
Rated Wattage	Maximum power (50 to 60Hz AC power to be applied for 1,000 hours at 85±2°C) for varistor voltage change within ±10% of the initial value.	Satisfy the specification
Maximum Clamping Voltage	Maximum voltage across varistor when 8/20µSec. rated current surge is applied.	Satisfy the specification
Capacitance	Varistor's capacitance at 1kHz, standard test condition.	For reference only.
Voltage Temperature Coefficient	$\frac{V_{1mA \text{ at } 85^{\circ}\text{C}} - V_{1mA \text{ at } 25^{\circ}\text{C}}}{V_{1mA \text{ at } 25^{\circ}\text{C}}} \times \frac{1}{60} \times 100 (\%/^{\circ}\text{C})$ V1mA : Actual Varistor Voltage	Within ±0.05%/°C
Insulation	Short circuit the two leads of varistor, and put the varistor body into lead balls (1.6mm diameter) leaving 2mm epoxy coating outside. Then, apply 2.5kVrms between the leads and the lead balls for 60±5 seconds.	The varistor shall withstand with no abnormality.

◆RELIABILITY CHARACTERISTICS

Item	Test Conditions	Specifications
Heat Cycle	Subject varistor to the following temperature cycles. -40°C for 30 minutes → Normal room temperature for 10 minutes → 85°C for 30 minutes → Normal room temperature for 10 minutes. This completes one cycle. The cycle shall be repeated 50 times total. After the cycles, the varistor shall be stored at normal room temperature for one hour. Then check the varistor voltage and the appearance.	ΔV1mA ≤±5% No appearance abnormality.
High Temperature Exposure	Store varistor at 125°C for 1,000 hours. After that, store the varistor at normal room temperature for one hour. Then check the varistor voltage.	ΔV1mA ≤±5%
Humidity Resistivity	Store at 40C, 90 to 95% RH for 1,000 hours. After that, store the varistor at normal room temperature for one hour. Then check the varistor voltage.	ΔV1mA ≤±5%
High Temperature Operation	Apply maximum applied voltage to varistor at 85°C for 1,000 hours. After that, store the varistor at normal room temperature for one hour. Then check the varistor voltage.	ΔV1mA ≤±10%

◆MECHANICAL CHARACTERISTICS

Item	Test Conditions	Specifications				
Soldering Heat Resistivity	Store varistor at normal room temperature. Dip the varistor leads to solder, at $350\pm 10^{\circ}\text{C}$ for $3\pm \frac{1}{0}$ seconds, up to 2.0~2.5 mm from the varistor body. After that, store the varistor at normal room temperature for 30 minutes, and measure the varistor voltage.	$\Delta V_{1\text{mA}} \leq \pm 5\%$ Vc : Actual varistor voltage No mechanical damages				
Solderability	Dip varistor leads to methanol solution (JIS K 1501, about 25%) of rosin (JIS Z 5902) for 5 to 10 seconds. Then, dip the lead to solder (JIS Z 3282 H60A or H63A) at 225 to 240°C, up to 2.0~2.5mm from the varistor body for 5 ± 0.5 seconds. Then, check the solderability.	At least, 95% of the surface dipped to solder shall be covered by new solder.				
Lead Pull Strength	Fix varistor body, and suspend specified weight toward direction of lead axis. <table style="margin-left: auto; margin-right: auto; border: none;"> <tr> <td style="text-align: center; border-bottom: 1px solid black;">Lead diameter</td> <td style="text-align: center; border-bottom: 1px solid black;">Force</td> </tr> <tr> <td style="text-align: center;">$\phi 0.6\text{mm}, \phi 0.8\text{mm}$</td> <td style="text-align: center;">10 N</td> </tr> </table>	Lead diameter	Force	$\phi 0.6\text{mm}, \phi 0.8\text{mm}$	10 N	No abnormality such as disconnection. $\Delta V_{1\text{mA}} \leq \pm 5\%$
Lead diameter	Force					
$\phi 0.6\text{mm}, \phi 0.8\text{mm}$	10 N					
Lead Bend Strength	The varistor shall be secured with its terminal kept vertical and the force specified below shall be applied in the axial direction. The terminal shall gradually be bend by 90 in one direction then back to original position. The damage of the terminal shall be visually examined. <table style="margin-left: auto; margin-right: auto; border: none;"> <tr> <td style="text-align: center; border-bottom: 1px solid black;">Lead diameter</td> <td style="text-align: center; border-bottom: 1px solid black;">Force</td> </tr> <tr> <td style="text-align: center;">$\phi 0.6\text{mm}, \phi 0.8\text{mm}$</td> <td style="text-align: center;">2.5 N</td> </tr> </table>	Lead diameter	Force	$\phi 0.6\text{mm}, \phi 0.8\text{mm}$	2.5 N	No remarkable damage as remarkable the inner ceramic element or terminal open.
Lead diameter	Force					
$\phi 0.6\text{mm}, \phi 0.8\text{mm}$	2.5 N					
Vibration Resistivity	Mount varistor body on vibrator, and conduct following vibration test. Peak-to-Peak amplitude : 1.5mm Vibration frequency range : 10Hz to 55Hz Sweeping time: Approximately one minute for 10Hz → 55Hz → 10Hz Direction and duration of vibration : Three directions of X, Y and Z. Two hours each. Six hours total.	No remarkable appearance abnormality. $\Delta V_{1\text{mA}} \pm 5\%$				
Flammability test	The varistor shall be subjected to 60 second applications of test flame. Burner : Bunsen gas burner 9000kcal / m ³ Diameter of flame nozzle : $\phi 9.5$ mm Position : The specimen shall be fixed horizontal. Point of application shall be approximately center of the specimen.	No catching fire, and no flaming drops.				

H Series

High Energy, Low Varistor Voltage Series

Operating Temperature Range: -40 to +125°C
Storage Temperature Range: -50 to +150°C

◆STANDARD RATINGS

Part Number	Previous Part Number (Just for your reference)	Max. Allowable Voltage			Max. Energy 20ms(J)	Max. Clamping Voltage		Varistor Voltage V1mA (V)
		Continuous		5 minutes		(A)	(V)	
		AC (Vrms)	DC (V)	DC (V)				
TND09H-220KB00AAA0	TNR9H220K	12	16	24	5	2	43	22 (20~24)
TND09H-270KB00AAA0	TNR9H270K	15	19	29			53	27 (24~30)
TND09H-330KB00AAA0	TNR9H330K	18	24	36			65	33 (30~36)
TND09H-390KB00AAA0	TNR9H390K	22	28	42			77	39 (35~43)
TND09H-470KB00AAA0	TNR9H470K	26	34	50			93	47 (42~52)
TND12H-220KB00AAA0	TNR12H220K	12	16	24	10	5	43	22 (20~24)
TND12H-270KB00AAA0	TNR12H270K	15	19	29			53	27 (24~30)
TND12H-330KB00AAA0	TNR12H330K	18	24	36			65	33 (30~36)
TND12H-390KB00AAA0	TNR12H390K	22	28	42			77	39 (35~43)
TND12H-470KB00AAA0	TNR12H470K	26	34	50			93	47 (42~52)
TND15H-220KB00AAA0	TNR15H220K	12	16	24	20	10	43	22 (20~24)
TND15H-270KB00AAA0	TNR15H270K	15	19	29			53	27 (24~30)
TND15H-330KB00AAA0	TNR15H330K	18	24	36			65	33 (30~36)
TND15H-390KB00AAA0	TNR15H390K	22	28	42			77	39 (35~43)
TND15H-470KB00AAA0	TNR15H470K	26	34	50			93	47 (42~52)
TND23H-220KB00AAA0	TNR23H220K	12	16	24	40	25	43	22 (20~24)
TND23H-270KB00AAA0	TNR23H270K	15	19	29			53	27 (24~30)
TND23H-330KB00AAA0	TNR23H330K	18	24	36			65	33 (30~36)
TND23H-390KB00AAA0	TNR23H390K	22	28	42			77	39 (35~43)
TND23H-470KB00AAA0	TNR23H470K	26	34	50			93	47 (42~52)

◆DIMENSIONS [mm]

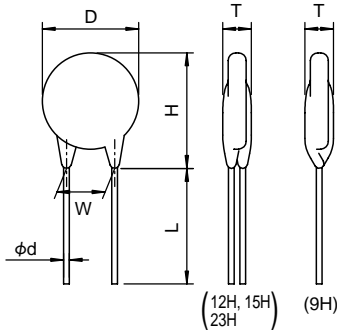

Type	D Max.	H Max.	W ±1.0	L Min.	φd
9H	10.0	14.0	5.0	25.0	0.6
12H	14.0	17.0	7.5	25.0	0.8
15H	17.0	20.0	7.5	25.0	0.8
23H	24.0	28.0	10.0	25.0	0.8

Type	T Max.
220K~330K	6.0
390K~470K	8.0

H Series

◆V-I CURVE

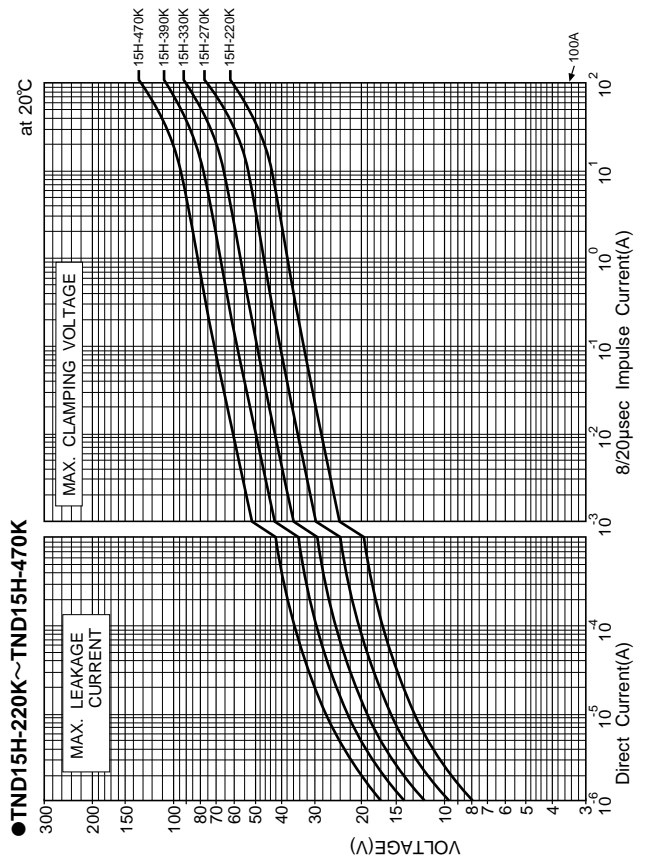
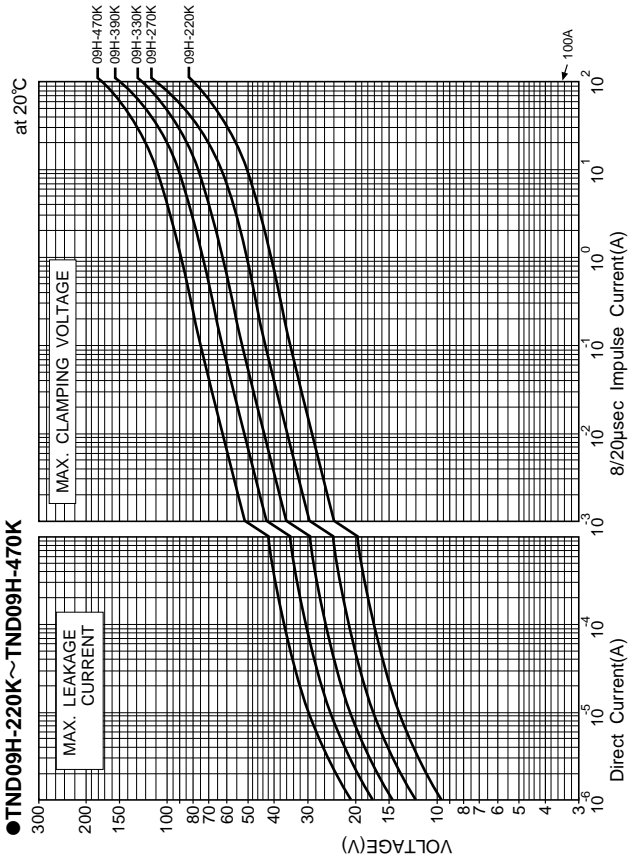
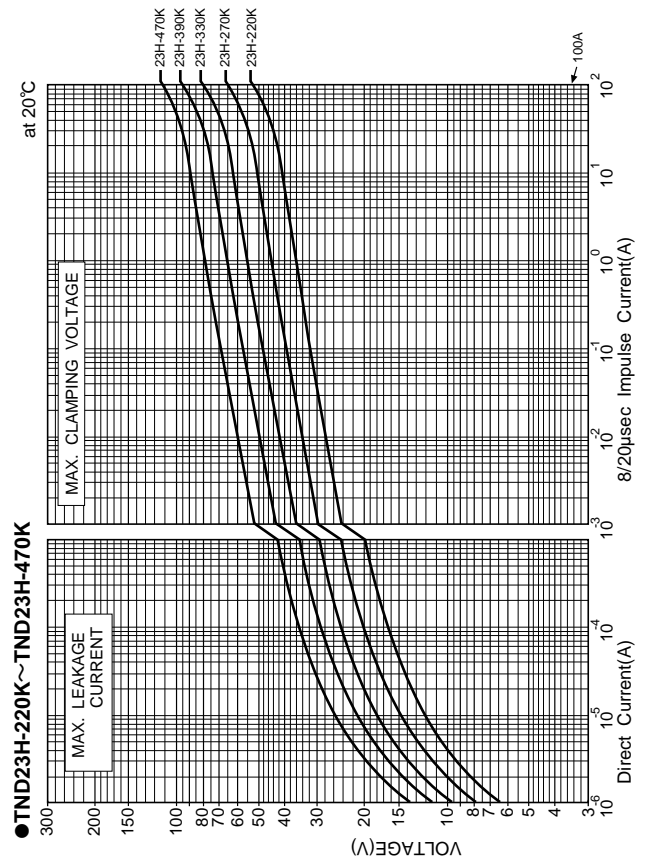
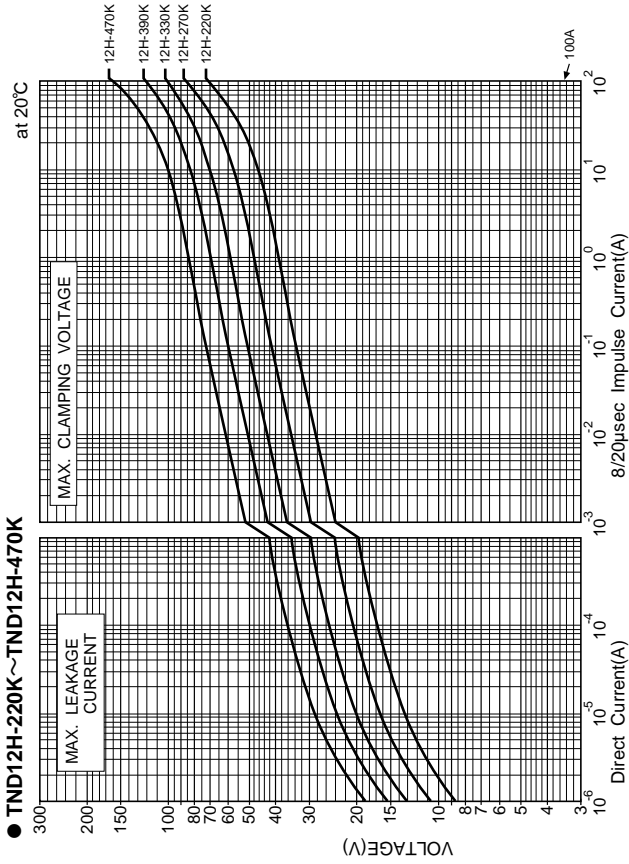



◆GENERAL SPECIFICATIONS

Operating Temperature Range: -40 to +125°C
Storage Temperature Range: -50 to +150°C

Item	Test Conditions	Specifications
Standard Test Condition	Ambient temperature : 20±15°C Relative humidity : 65±20% RH if there is any doubt about the results, measurement shall be made within the following limits. Ambient temperature : 20±5°C Relative humidity : 65±20% RH	
Varistor Voltage	The voltage between the two terminals measured at 1mA DC is called Varistor Voltage. The measurement shall be made as fast as possible to avoid heat effecton.	Satisfy the specification.
Maximum Allowable Voltage	Maximum continuous sinusoidal RMS voltage or Maximum continuous DC voltage which may be applied.	Refer to RATINGS.
Maximum applicable voltage for a short period (5 minutes)	Maximum DC voltage to be applied for only 5 minutes.	Refer to RATINGS.
Maximum Clamping Voltage	The maximum voltage between the terminals, measured standard impluse current (8/20 μs).	Satisfy the specification.
Maximum Energy	Maximum energy within the ±10% varistor voltage change when 1 impulse 20 msec long is applied.	Satisfy the specification.
Temperature Coefficient	$\frac{V_{1mA \text{ at } 85^\circ\text{C}} - V_{1mA \text{ at } 25^\circ\text{C}}}{V_{1mA \text{ at } 25^\circ\text{C}}} \times \frac{1}{60} \times 100 (\%/^\circ\text{C})$	Within ±0.05% / °C

◆MECHANICAL CHARACTERISTICS

Item	Test Conditions	Specifications
Terminal Pull Strength	After gradually applying the force keeping the unit fixed for 10±1 second in axial direction, the damage of the terminals shall be visually examined. $\frac{\text{Lead diameter}}{\phi 0.6\text{mm. } \phi 0.8\text{mm}} \quad \frac{\text{Force}}{10 \text{ N}}$	No remarkable damage
Terminal Bending Strength	The unit shall be secured with its terminal kept vertical and the weight specified below be applied in the axial direction. The terminal shall gradually be bend by 90° in one direction then 90° in the opposite direction, and again back to original position. The damage of the terminal shall be visually examined. $\frac{\text{Lead diameter}}{\phi 0.6\text{mm. } \phi 0.8\text{mm}} \quad \frac{\text{Force}}{5 \text{ N}}$	No remarkable damage
Vibration	After repeatedly applying a single harmonic vibration (amplitude : 0.75mm) double amplitude : 1.5mm with 1 minute vibration frequency cycle (10Hz→500Hz→10Hz) to each three perpendicular directions for 2 hours. Total 6 hours. The devices shall be visually examined.	No remarkable damage
Solderability	Dipping the terminal to a Rosin depth for 5 to 10 seconds. After dipping the terminal to a depth of 2.0 to 2.5mm from the body in a soldering bath of 230±5°C for 5±0.5 seconds, the terminal shall be visually examined.	75% of the terminals should be covered with solder uniformly.
Resistance to Soldering Heat	The terminal shall be dipped into a soldering bath of 350±10°C to a depth of 2.0 to 2.5mm from the body and be held there for 3± $\frac{1}{2}$ seconds. or The terminal shall be dipped into a soldering bath of 260±5°C to a depth of 2.0 to 2.5mm from the body and be held there for 10±1 seconds.	$\Delta V_{1mA} \leq \pm 5\%$ No outstanding damage



H Series

◆ENVIRONMENTAL CHARACTERISTICS

Item	Test Conditions	Specifications
High Temperature Storage (Dry heat)	The specimen shall be subjected 150±2°C for 1000±12 hours without load.	$\Delta V 1mA \leq \pm 10\%$
Damp heat (Humidity)	The specimen shall be subjected to 60±2°C, 90 to 95%RH for 1000±12 hours without load.	$\Delta V 1mA \leq \pm 10\%$
Temperature Cycle	The temperature cycle shown below shall be repeated 50 cycles. -40C±3°C, 30 minutes ↔ +150°C±2°C, 30 minutes	$\Delta V 1mA \leq \pm 10\%$ No remarkable damage
High Temperature Operating	The specimen shall be subjected to 125±2°C with the maximum allowable voltage for 1000±12 hours.	$\Delta V 1mA \leq \pm 20\%$
Damp heat Operating	The specimen shall be subjected to 60±2°C, 90 to 95%RH with the maximum allowable voltage for 1000±12 hours.	$\Delta V 1mA \leq \pm 10\%$

Varistor voltage change of forward direction shall be measured in the test of unipole surge life and DC load life.

Varistor voltage change is measured after stored at Standard Test Conditions for 1 to 2 hours.

Note : For 42V battery line, please contact our sales office.

GF Series

GF Series are combined TNR G Series with Thermal Fuse



Operating Temperature Range: -40 to +85°C

Storage Temperature Range: -50 to +125°C

◆STANDARD RATINGS

Part Number	Previous Part Number (Just for your reference)	Maximum Ratings					Max. Clamping Voltage	Capacitance Typical @1kHz	Varistor Voltage V1mA	T Max.
		Max. Allowable Voltage		Max. Peak Current	Max. Energy	Rated Wattage				
15GF Type		AC (Vrms)	DC (V)	8/20μs(A)	2ms(J)	(W)	V50A (V)	(pF)	(V)	(mm)
TND15GF271KB00AAA0	TNR15GF271K	175	225		50	0.6	440	680	270 (243~297)	9
TND15GF471KB00AAA0	TNR15GF471K	300	385	2500A/2 times	80	0.6	765	450	470 (423~517)	10
TND15GF821KB00AAA0	TNR15GF821K	510	670		110	0.6	1,340	280	820 (738~902)	12
23GF Type		AC (Vrms)	DC (V)	8/20μs(A)	2ms(J)	(W)	V100A (V)	(pF)	(V)	(mm)
TND23GF271KB00AAA0	TNR23GF271K	175	225		90	0.8	440	1,850	270 (243~297)	9
TND23GF471KB00AAA0	TNR23GF471K	300	385	4000A/2 times	150	1.0	765	1,200	470 (423~517)	10
TND23GF821KB00AAA0	TNR23GF821K	510	670		190	1.5	1,340	800	820 (738~902)	12

◆DIMENSIONS [mm]

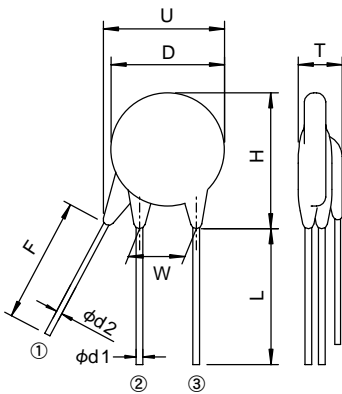

	15GF	23GF
D	18 Max.	25 Max.
T	9 to 12	
H	22 Max.	32 Max.
W	7.5±1	10±1
L	30 Min.	
U	23 Max.	28 Max.
F	22 Min.	
φd1	0.8	
φd2	0.5	0.6

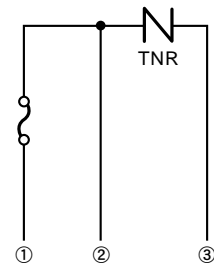



METAL OXIDE VARISTORS TNR®

32HP Series

High Peak Current with tabs



Operating Temperature Range: -40 to +85°C

Storage Temperature Range: -50 to +125°C

STANDARD RATINGS

Part Number	Previous Part Number (Just for your reference)	Maximum Ratings					Max. Clamping Voltage V200A (V)	Capacitance Typical @1kHz (pF)	Varistor Voltage V1mA (V)
		Max. Allowable Voltage		Max. Peak Current	Max. Energy	Rated Wattage			
		AC (Vrms)	DC (V)	8/20μs(kA)	2ms(J)	(W)			
TNT32HP221KB00AAA0	TNR32HP221K310	140	180	25,000A/1 time	200	1.2	360	5,500	220 (198~ 242)
TNT32HP241KB00AAA0	TNR32HP241K310	150	200		240		395	4,800	240 (216~ 264)
TNT32HP271KB00AAA0	TNR32HP271K310	175	225		260		445	4,200	270 (243~ 297)
TNT32HP391KB00AAA0	TNR32HP391K310	250	320		350		650	3,500	390 (351~ 429)
TNT32HP431KB00AAA0	TNR32HP431K310	275	350		400		710	2,700	430 (387~ 473)
TNT32HP471KB00AAA0	TNR32HP471K310	300	385		410		775	2,600	470 (423~ 517)
TNT32HP511KB00AAA0	TNR32HP511K310	315	420		420		840	2,400	510 (459~ 561)
TNT32HP681KB00AAA0	TNR32HP681K310	420	560		450		1,120	2,100	680 (612~ 748)
TNT32HP751KB00AAA0	TNR32HP751K310	460	615		500		1,240	2,000	750 (675~ 825)
TNT32HP821KB00AAA0	TNR32HP821K310	510	670		545		1,355	1,800	820 (738~ 902)
TNT32HP911KB00AAA0	TNR32HP911K310	550	745	600	1,500	1,700	910 (819~1,001)		
TNT32HP102KB00AAA0	TNR32HP102K310	625	825	620	1,650	1,000	1,000 (900~1,100)		
TNT32HP112KB00AAA0	TNR32HP112K310	680	895	640	1,815	800	1,100 (990~1,210)		

DIMENSIONS [mm (in.)]

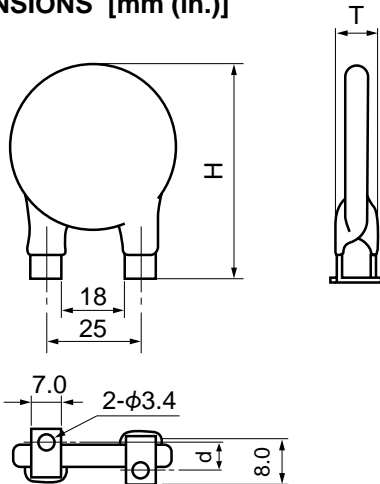

Part Number	H Max.	T Max.	d ±1.0
TNT32HP221KB00AAA0	46.0	7.5	6.8
TNT32HP241KB00AAA0	46.0	7.5	6.7
TNT32HP271KB00AAA0	46.0	7.5	6.5
TNT32HP391KB00AAA0	46.0	7.5	5.8
TNT32HP431KB00AAA0	46.0	7.5	5.6
TNT32HP471KB00AAA0	46.0	7.5	5.4
TNT32HP511KB00AAA0	46.0	10.0	5.2
TNT32HP681KB00AAA0	46.0	10.0	4.2
TNT32HP751KB00AAA0	46.0	10.0	3.9
TNT32HP821KB00AAA0	46.0	10.0	3.5
TNT32HP911KB00AAA0	46.0	10.0	3.0
TNT32HP102KB00AAA0	46.0	11.0	2.5
TNT32HP112KB00AAA0	46.0	11.0	1.9

V-I CURVE

● TNT32HP221K~TNT32HP112K

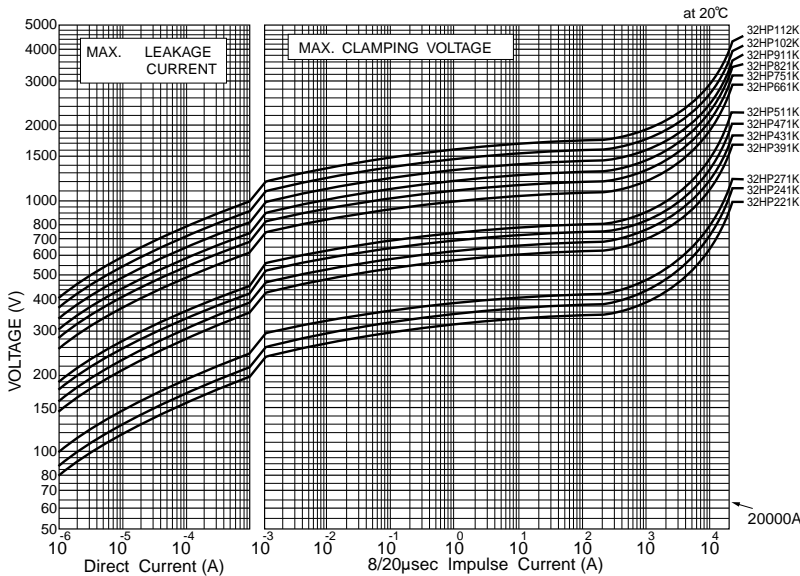

PULSE LIFE TIME RATINGS

● TNT32HP221K~TNT32HP112K

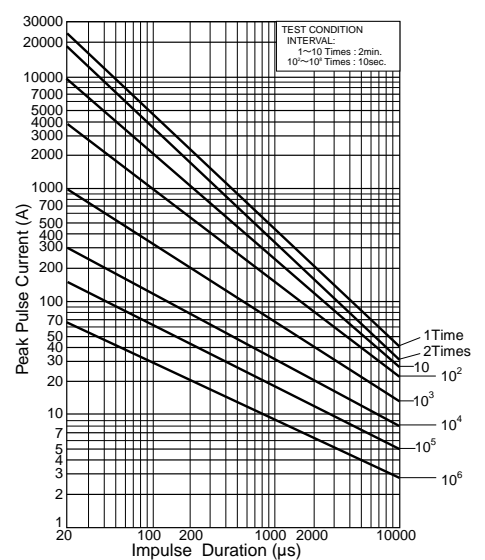

C Series

Chip Type For Direct Surface Mounting (5C and 7C Type)

 Operating Temperature Range: -40 to +125°C
 Storage Temperature Range: -50 to +150°C

◆STANDARD RATINGS (Type 5C, 7C)

Part Number	Previous Part Number (Just for your reference)	Maximum Ratings					Max. Clamping Voltage		Varistor Voltage V _{0.1mA}	T±1 (mm)
		Max. Allowable Voltage		Max. Peak Current	Max. Energy	Rated Wattage	(A)	(V)		
		AC (Vrms)	DC (V)	8/20μs(A)	2ms(J)	(W)			(V)	
TNC05C-220KB00AAA0	TNR5C220K	14	18	25A/2 times	0.16	0.005	0.5	48	22 (20~24)	1.5
TNC05C-270KB00AAA0	TNR5C270K	17	22		0.20			60	27 (24~30)	
TNC05C-330KB00AAA0	TNR5C330K	20	26		0.24			73	33 (30~36)	
TNC05C-390KB00AAA0	TNR5C390K	25	30		0.32			86	39 (35~43)	
TNC05C-470KB00AAA0	TNR5C470K	30	37		0.34			104	47 (42~52)	
TNC05C-560KB00AAA0	TNR5C560K	35	44	0.37	123	56 (50~62)	2.0			
TNC05C-680KB00AAA0	TNR5C680K	40	55	0.43	150	68 (61~75)				
TNC05C-820KB00AAA0	TNR5C820K	50	65	0.65	145	82 (74~90)	1.5			
TNC05C-101KB00AAA0	TNR5C101K	60	85	0.65	175	100 (90~110)				
TNC05C-121KB00AAA0	TNR5C121K	75	100	0.65	210	120 (108~132)				
TNC05C-151KB00AAA0	TNR5C151K	95	125	1.0	260	150 (135~165)				
TNC05C-181KB00AAA0	TNR5C181K	110	145	100A/2 times	1.0	0.05		2.5	325	180 (162~198)
TNC05C-201KB00AAA0	TNR5C201K	130	170	1.0	355	200 (180~220)				
TNC05C-221KB00AAA0	TNR5C221K	140	180	1.5	380	220 (198~242)				
TNC05C-241KB00AAA0	TNR5C241K	150	200	1.5	415	240 (216~264)				
TNC05C-271KB00AAA0	TNR5C271K	175	225	2.0	475	270 (243~297)				
TNC07C-220KB00AAA0	TNR7C220K	14	18	0.4	48	22 (20~24)		1.5		
TNC07C-270KB00AAA0	TNR7C270K	17	22	0.5	60	27 (24~30)				
TNC07C-330KB00AAA0	TNR7C330K	20	26	0.6	73	33 (30~36)				
TNC07C-390KB00AAA0	TNR7C390K	25	30	60A/2 times	0.8	0.01	1.0		86	39 (35~43)
TNC07C-470KB00AAA0	TNR7C470K	30	37	1.0	104	47 (42~52)				
TNC07C-560KB00AAA0	TNR7C560K	35	44	1.1	123	56 (50~62)	2.0			
TNC07C-680KB00AAA0	TNR7C680K	40	55	1.3	150	68 (61~75)				
TNC07C-820KB00AAA0	TNR7C820K	50	65	2	145	82 (74~90)	1.5			
TNC07C-101KB00AAA0	TNR7C101K	60	85	2	175	100 (90~110)				
TNC07C-121KB00AAA0	TNR7C121K	75	100	3	210	120 (108~132)				
TNC07C-151KB00AAA0	TNR7C151K	95	125	3	260	150 (135~165)				
TNC07C-181KB00AAA0	TNR7C181K	110	145	4	325	180 (162~198)				
TNC07C-201KB00AAA0	TNR7C201K	130	170	5	355	200 (180~220)				
TNC07C-221KB00AAA0	TNR7C221K	140	180	250A/2 times	5	0.1		5.0	380	220 (198~242)
TNC07C-241KB00AAA0	TNR7C241K	150	200	5	415	240 (216~264)				
TNC07C-271KB00AAA0	TNR7C271K	175	225	6	475	270 (243~297)				
TNC07C-331KB00AAA0	TNR7C331K	210	270	8	600	330 (297~363)				
TNC07C-361KB00AAA0	TNR7C361K	230	300	8	620	360 (324~396)		2.0		
TNC07C-391KB00AAA0	TNR7C391K	250	320	8	675	390 (351~429)				
TNC07C-431KB00AAA0	TNR7C431K	275	350	10	745	430 (387~473)		2.5		
TNC07C-471KB00AAA0	TNR7C471K	300	385	10	810	470 (423~517)				

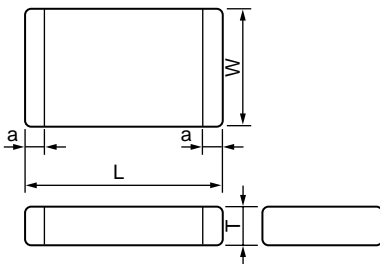
◆DIMENSIONS [mm]

Type	L±0.3	W±0.3	a Nom.
5C	8.0	6.3	0.8
7C	10.0	8.0	1.0
9C	12.5	10.0	1.0
12C	16.0	12.5	1.0

◆Precautions for pattern design and soldering

Do not line under the chip varistors at pattern design.
 TNR C Series is designed for reflow soldering only.
 Peak temperature of reflow soldering profile shall be 220 to 240°C during 5 to 10 sec.



C Series

Chip Type For Direct Surface Mounting (9C and 12C Type)

Operating Temperature Range: -40 to +125°C
Storage Temperature Range: -50 to +150°C

◆STANDARD RATINGS (Type 9C, 12C)

Part Number	Previous Part Number (Just for your reference)	Maximum Ratings					Max. Clamping Voltage		Varistor Voltage V _{1mA}	T±1		
		Max. Allowable Voltage		Max. Peak Current	Max. Energy	Rated Wattage	(A)	(V)				
		AC (Vrms)	DC (V)	8/20μs(A)	2ms(J)	(W)			(V)	(mm)		
TNC09C-220KB00AAA0	TNR9C220K	14	18	125A/2 times	1.0	0.02	2.0	43	22 (20~ 24)	1.5		
TNC09C-270KB00AAA0	TNR9C270K	17	22		1.0			53	27 (24~ 30)			
TNC09C-330KB00AAA0	TNR9C330K	20	26		1.2			65	33 (30~ 36)			
TNC09C-390KB00AAA0	TNR9C390K	25	30		1.5			77	39 (35~ 43)			
TNC09C-470KB00AAA0	TNR9C470K	30	37		1.8			93	47 (42~ 52)			
TNC09C-560KB00AAA0	TNR9C560K	35	44	2.2	2.0	10.0	110	56 (50~ 62)	2.0			
TNC09C-680KB00AAA0	TNR9C680K	40	55	2.5			135	68 (61~ 75)				
TNC09C-820KB00AAA0	TNR9C820K	50	65	4	600A/2 times	0.2	135	82 (74~ 90)	1.5			
TNC09C-101KB00AAA0	TNR9C101K	60	85	4			164	100 (90~110)				
TNC09C-121KB00AAA0	TNR9C121K	75	100	5			195	120 (108~132)				
TNC09C-151KB00AAA0	TNR9C151K	95	125	6			245	150 (135~165)				
TNC09C-181KB00AAA0	TNR9C181K	110	145	8			295	180 (162~198)				
TNC09C-201KB00AAA0	TNR9C201K	130	170	10			330	200 (180~220)				
TNC09C-221KB00AAA0	TNR9C221K	140	180	10			360	220 (198~242)				
TNC09C-241KB00AAA0	TNR9C241K	150	200	10			390	240 (216~264)				
TNC09C-271KB00AAA0	TNR9C271K	175	225	12			440	270 (243~297)				
TNC09C-331KB00AAA0	TNR9C331K	210	270	15			540	330 (297~363)				
TNC09C-361KB00AAA0	TNR9C361K	230	300	16			590	360 (324~396)				
TNC09C-391KB00AAA0	TNR9C391K	250	320	17			640	390 (351~429)				
TNC09C-431KB00AAA0	TNR9C431K	275	350	20			700	430 (387~473)				
TNC09C-471KB00AAA0	TNR9C471K	300	385	20	765	470 (423~517)						
TNC12C-220KB00AAA0	TNR12C220K	14	18	2.0	250A/2 times	0.05	43	22 (20~ 24)	1.5			
TNC12C-270KB00AAA0	TNR12C270K	17	22	2.5			53	27 (24~ 30)				
TNC12C-330KB00AAA0	TNR12C330K	20	26	3.0			65	33 (30~ 36)				
TNC12C-390KB00AAA0	TNR12C390K	25	30	3.5			77	39 (35~ 43)				
TNC12C-470KB00AAA0	TNR12C470K	30	37	4.5			93	47 (42~ 52)				
TNC12C-560KB00AAA0	TNR12C560K	35	44	5.5			110	56 (50~ 62)				
TNC12C-680KB00AAA0	TNR12C680K	40	55	6.5			135	68 (61~ 75)				
TNC12C-820KB00AAA0	TNR12C820K	50	65	8			25.0	0.4		135	82 (74~ 90)	1.5
TNC12C-101KB00AAA0	TNR12C101K	60	85	10						165	100 (90~110)	
TNC12C-121KB00AAA0	TNR12C121K	75	100	12						195	120 (108~132)	
TNC12C-151KB00AAA0	TNR12C151K	95	125	16						245	150 (135~165)	
TNC12C-181KB00AAA0	TNR12C181K	110	145	18						295	180 (162~198)	
TNC12C-201KB00AAA0	TNR12C201K	130	170	20						330	200 (180~220)	
TNC12C-221KB00AAA0	TNR12C221K	140	180	25	360	220 (198~242)						
TNC12C-241KB00AAA0	TNR12C241K	150	200	25	390	240 (216~264)						
TNC12C-271KB00AAA0	TNR12C271K	175	225	30	440	270 (243~297)						
TNC12C-331KB00AAA0	TNR12C331K	210	270	35	540	330 (297~363)						
TNC12C-361KB00AAA0	TNR12C361K	230	300	35	590	360 (324~396)						
TNC12C-391KB00AAA0	TNR12C391K	250	320	40	640	390 (351~429)						
TNC12C-431KB00AAA0	TNR12C431K	275	350	45	700	430 (387~473)						
TNC12C-471KB00AAA0	TNR12C471K	300	385	45	765	470 (423~517)						

◆V-I CURVE

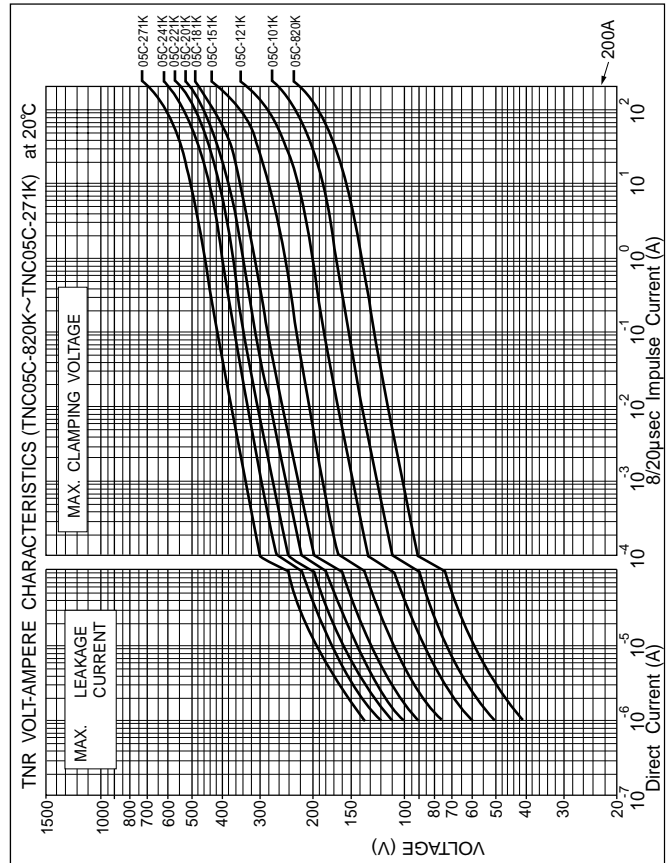
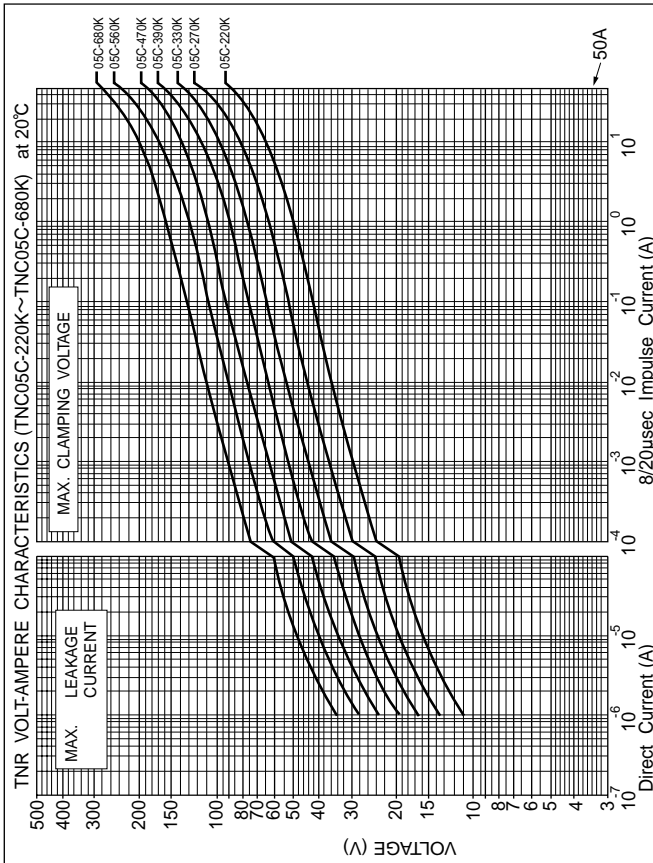
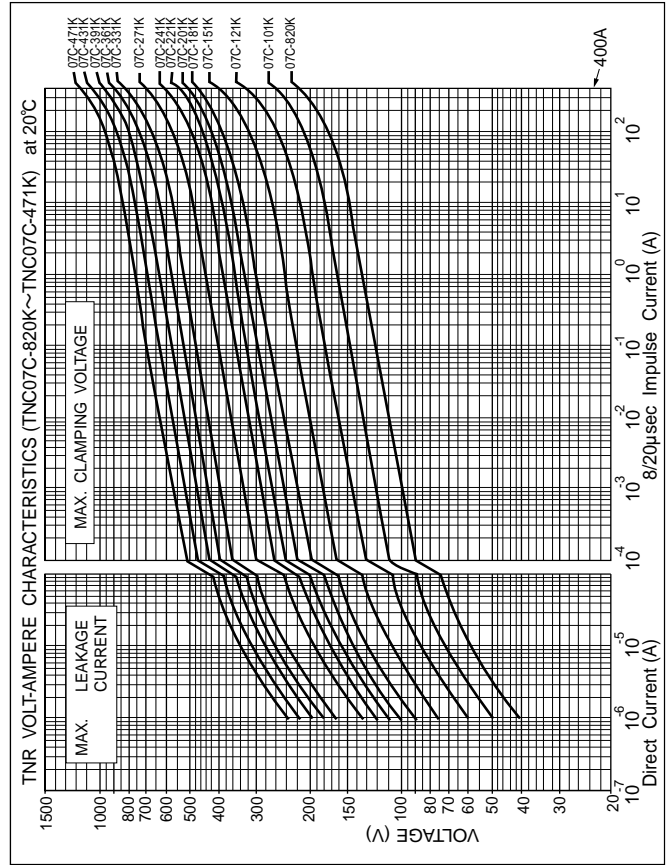
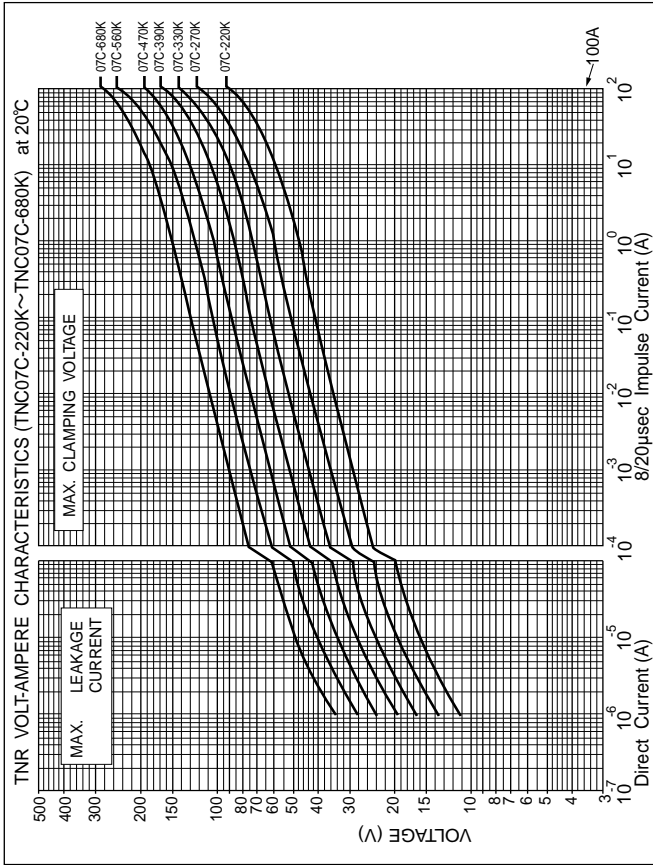

◆V-I CURVE

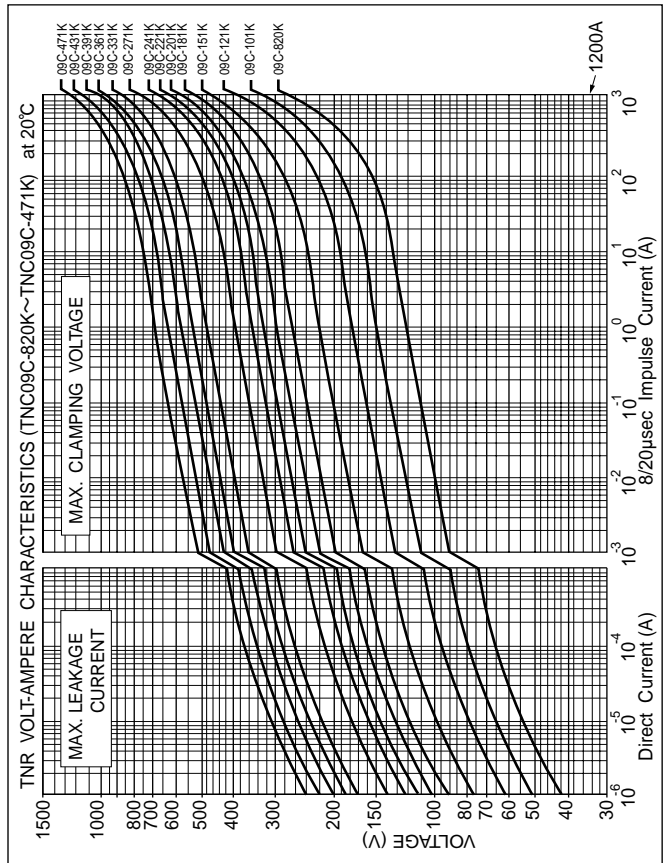
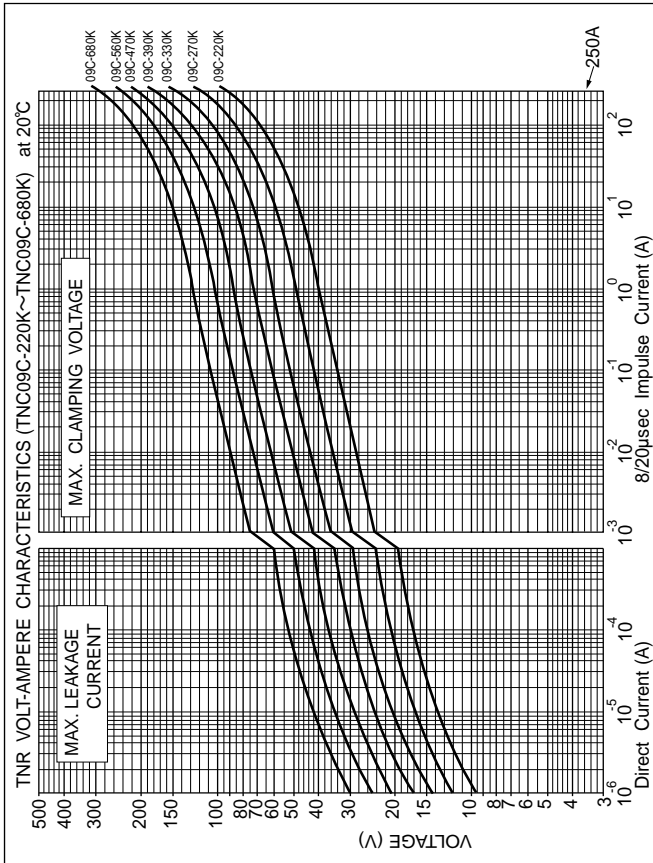
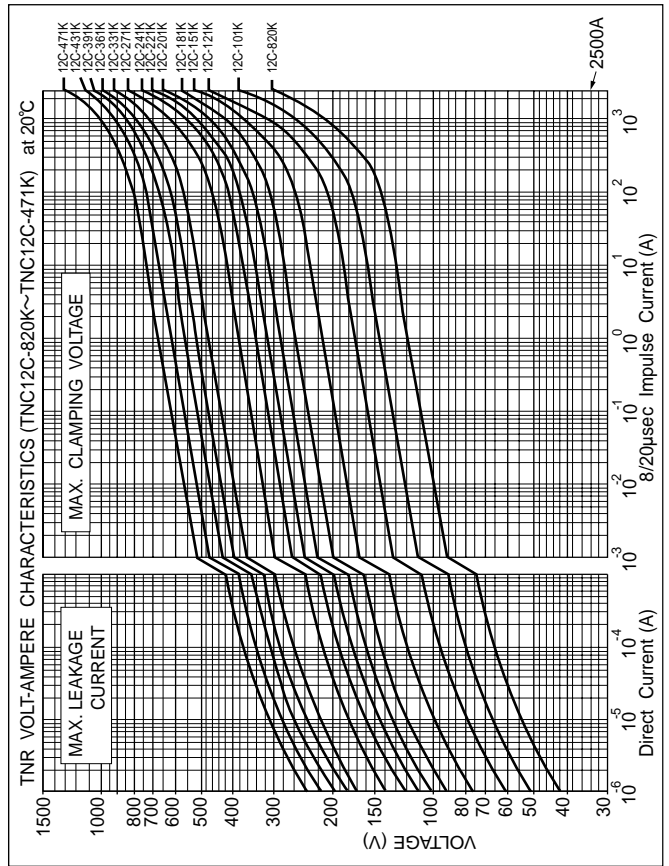
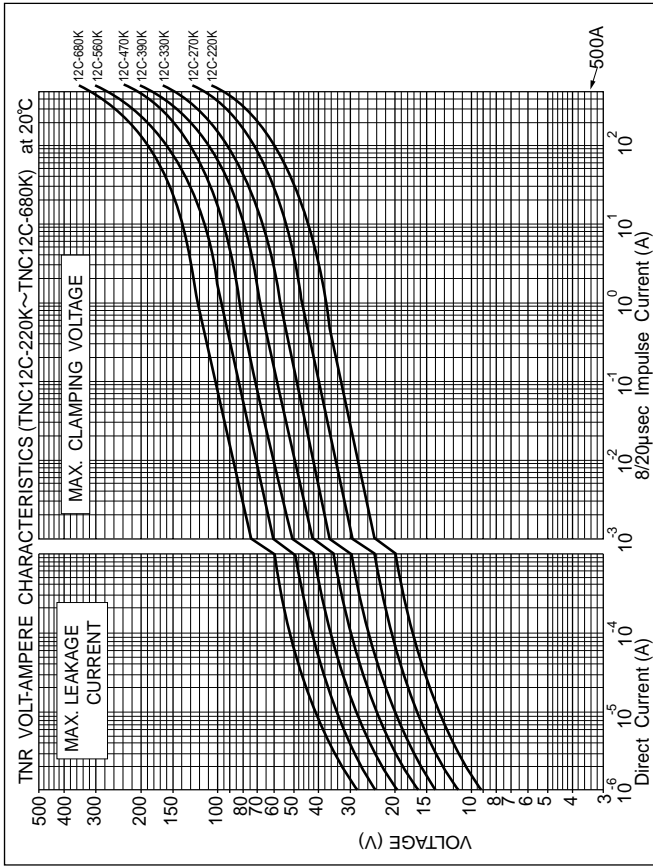

A Series

High Varistor Voltage (Axial Lead Type)

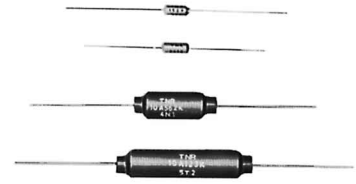

STANDARD RATINGS

Part Number	Previous Part Number (Just for your reference)	Maximum Ratings					Max. Clamping Voltage V _{2A} (V)	Varistor Voltage V _{0.1mA} (V)	H Max. (mm)
		Max. Allowable Voltage		Max. Peak Current	Max. Energy	Rated Wattage			
4A Type		AC (Vrms)	DC (V)	8/20μs(A)	2ms(J)	(W)			
TNL04A-122KB00AAA0	TNR4A122K	620	880		1.8		2,200	1,200 (1,080~ 1,320)	11
TNL04A-152KB00AAA0	TNR4A152K	780	1,100	40A/1 time	2.0	0.05	2,600	1,500 (1,350~ 1,650)	12
TNL04A-182KB00AAA0	TNR4A182K	930	1,300	20A/2 times	2.5		3,100	1,800 (1,620~ 1,980)	13
TNL04A-202KB00AAA0	TNR4A202K	1,040	1,450		3.0		3,500	2,000 (1,800~ 2,200)	15
10A Type		AC (Vrms)	DC (V)	8/20μs(A)	2ms(J)		(W)	V _{5A} (V)	(V)
TNL10A-472KB00AAA0	TNR10A472K	2,200	3,100		10	0.5	8,700	4,700 (4,230~ 5,170)	40
TNL10A-562KB00AAA0	TNR10A562K	2,600	3,700		10		10,000	5,600 (5,040~ 6,160)	
TNL10A-582KB00AAA0	TNR10A682K	3,200	4,500	100A/1 time	10		12,000	6,800 (6,120~ 7,480)	
TNL10A-822KB00AAA0	TNR10A822K	3,900	5,500	50A/2 times	10		16,000	8,200 (7,380~ 9,020)	50
TNL10A-103KB00AAA0	TNR10A103K	4,700	6,700		15		19,500	10,000 (9,000~11,000)	55
TNL10A-123KB00AAA0	TNR10A123K	5,700	8,100		15		21,500	12,000 (10,800~13,200)	

Operating Temperature Range -40 to +85°C Storage Temperature Range -50 to +105°C

DIMENSIONS [mm (in.)]

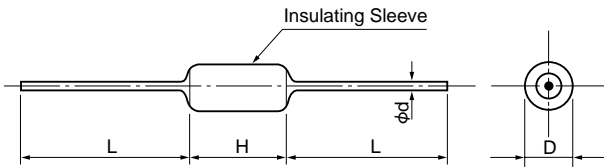

Type	4A Type	10A Type
D	4±1	10±1
L	25 Min.	30 Min.
φd	0.6	1

V-I CURVE

●TNL04A-122K~202K

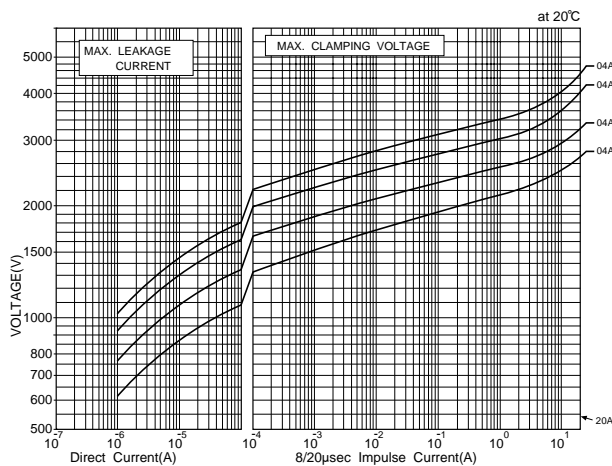

V-I CURVE

●TNL10A-472K~123K

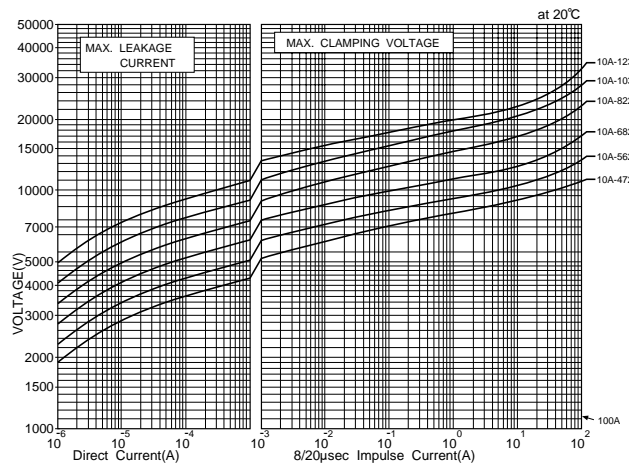

E Series

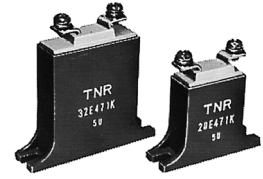

◆FEATURES

- Excellent clamping voltage characteristic and fast response time (<50nsec.) when subjected to impulse surges.
- No follow current.
- Any voltage rating within a V1mA range from 200V to 1,100V available. (V1mA : varistor voltage.)
- Bilateral and symmetrical V- I characteristics curve.
- The TNR can, therefore, be used both in AC and DC circuits, for protection of either positive or negative transients.
- Large withstanding peak current 8,000A-25,000A(8/20µsec.).

◆APPLICATIONS

- Protection of semiconductors such as transistors, diodes, ICs, thyristors, triacs, etc.
- Protection of various equipment including:
 - *Broadcasting, communications equipment.
 - *Traffic and railway signal systems.
 - *Automatic control devices for power distribution.
 - *Waterworks.
 - *Home entertainment equipment.
- Surge absorption of relays and electromagnetic valves.
- Absorption of surges generated within equipment such as TVs.

◆DIMENSIONS [mm (in.)]

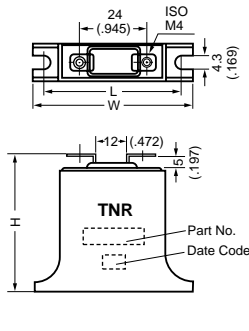

Type	W	H	L
20E	48±1 (1.890±0.039)	42±1 (1.653±0.039)	39±1 (1.535±0.039)
32E	60±1 (2.362±0.039)	55±1 (2.165±0.039)	51±1 (2.008±0.039)

◆STANDARD RATINGS

Part Number	Previous Part Number (Just for your reference)	Maximum Ratings					Max. Clamping Voltage	Capacitance Typical @1kHz	Varistor Voltage V1mA	
		Max. Allowable Voltage		Max. Peak Current	Max. Energy	Rated Wattage				
20E Series		AC (Vrms)	DC (V)	8/20µs (kA)	2ms (J)	(W)	V100A (V)	(pF)	(V)	
TNB20E-221KB00AAA0	TNR20E221K	140	180	8,000A/1 time	80	0.8	360	2,200	220 (198~ 242)	
TNB20E-241KB00AAA0	TNR20E241K	150	200		95		395	1,500	240 (216~ 264)	
TNB20E-271KB00AAA0	TNR20E271K	175	225		100		445	1,400	270 (243~ 297)	
TNB20E-391KB00AAA0	TNR20E391K	250	320		130		650	1,200	390 (351~ 429)	
TNB20E-431KB00AAA0	TNR20E431K	275	350		140		710	1,000	430 (387~ 473)	
TNB20E-471KB00AAA0	TNR20E471K	300	385		150		775	950	470 (423~ 517)	
TNB20E-511KB00AAA0	TNR20E511K	315	420		160		840	930	510 (459~ 561)	
TNB20E-681KB00AAA0	TNR20E681K	420	560		10,000A/2 times		175	1,120	850	680 (612~ 748)
TNB20E-751KB00AAA0	TNR20E751K	460	615				190	1,240	800	750 (675~ 825)
TNB20E-821KB00AAA0	TNR20E821K	510	670				215	1,355	700	820 (738~ 902)
TNB20E-911KB00AAA0	TNR20E911K	550	745	240		1,500	600	910 (819~1,001)		
TNB20E-102KB00AAA0	TNR20E102K	625	825	245		1,650	400	1,000 (900~1,100)		
TNB20E-112KB00AAA0	TNR20E112K	680	895	250		1,815	350	1,100 (990~1,210)		
32E Series		AC (Vrms)	DC (V)	8/20µs (kA)	2ms (J)	(W)	V200A (V)	(pF)	(V)	
TNB32E-221KB00AAA0	TNR32E221K	140	180	25,000A/1 time	200	1.2	360	5,500	220 (198~ 242)	
TNB32E-241KB00AAA0	TNR32E241K	150	200		240		395	4,800	240 (216~ 264)	
TNB32E-271KB00AAA0	TNR32E271K	175	225		260		445	4,200	270 (243~ 297)	
TNB32E-391KB00AAA0	TNR32E391K	250	320		350		650	3,500	390 (351~ 429)	
TNB32E-431KB00AAA0	TNR32E431K	275	350		400		710	2,700	430 (387~ 473)	
TNB32E-471KB00AAA0	TNR32E471K	300	385		410		775	2,600	470 (423~ 517)	
TNB32E-511KB00AAA0	TNR32E511K	315	420		420		840	2,400	510 (459~ 561)	
TNB32E-681KB00AAA0	TNR32E681K	420	560		20,000A/2 times		450	1,120	2,100	680 (612~ 748)
TNB32E-751KB00AAA0	TNR32E751K	460	615				500	1,240	2,000	750 (675~ 825)
TNB32E-821KB00AAA0	TNR32E821K	510	670				545	1,355	1,800	820 (738~ 902)
TNB32E-911KB00AAA0	TNR32E911K	550	745	600		1,500	1,700	910 (819~1,001)		
TNB32E-102KB00AAA0	TNR32E102K	625	825	620		1,650	1,000	1,000 (900~1,100)		
TNB32E-112KB00AAA0	TNR32E112K	680	895	640		1,815	800	1,100 (990~1,210)		

Operating Temperature Range -40 to +85°C Storage Temperature Range -40 to +110°C



E Series

◆V-I CURVE

●TNB20E-221K~112K

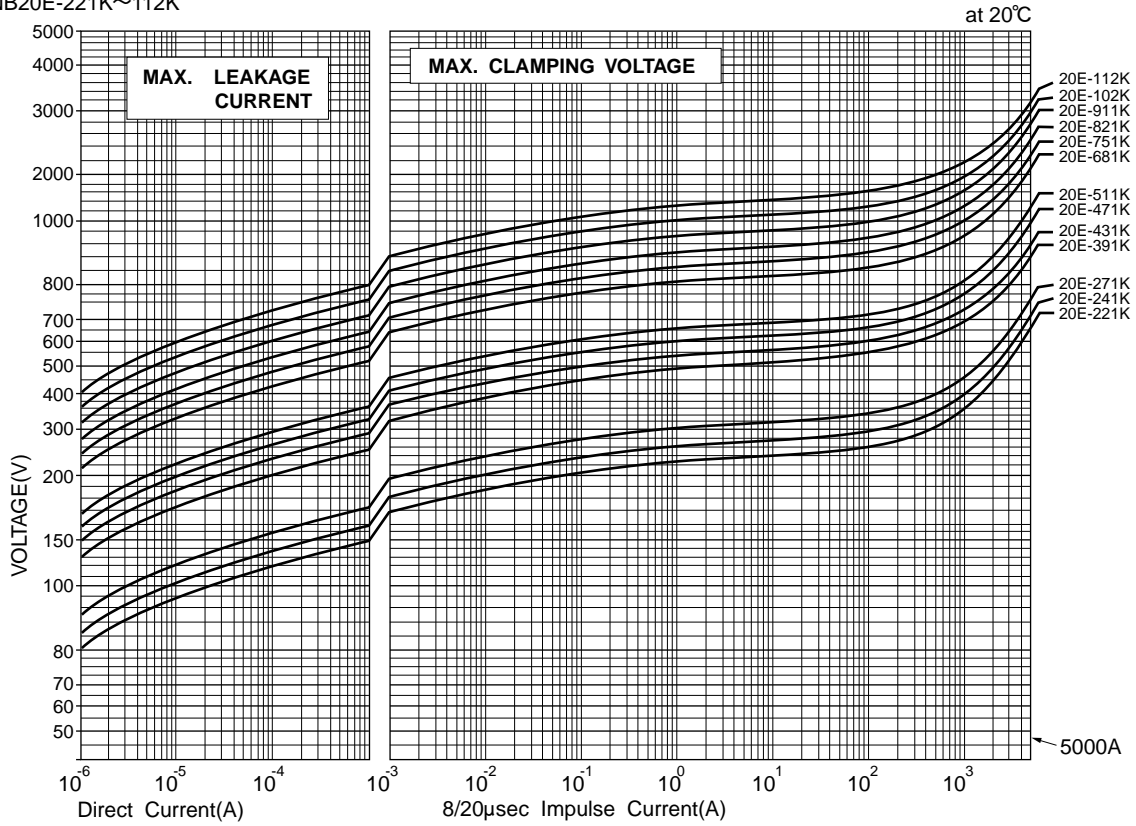

●TNB32E-221K~112K

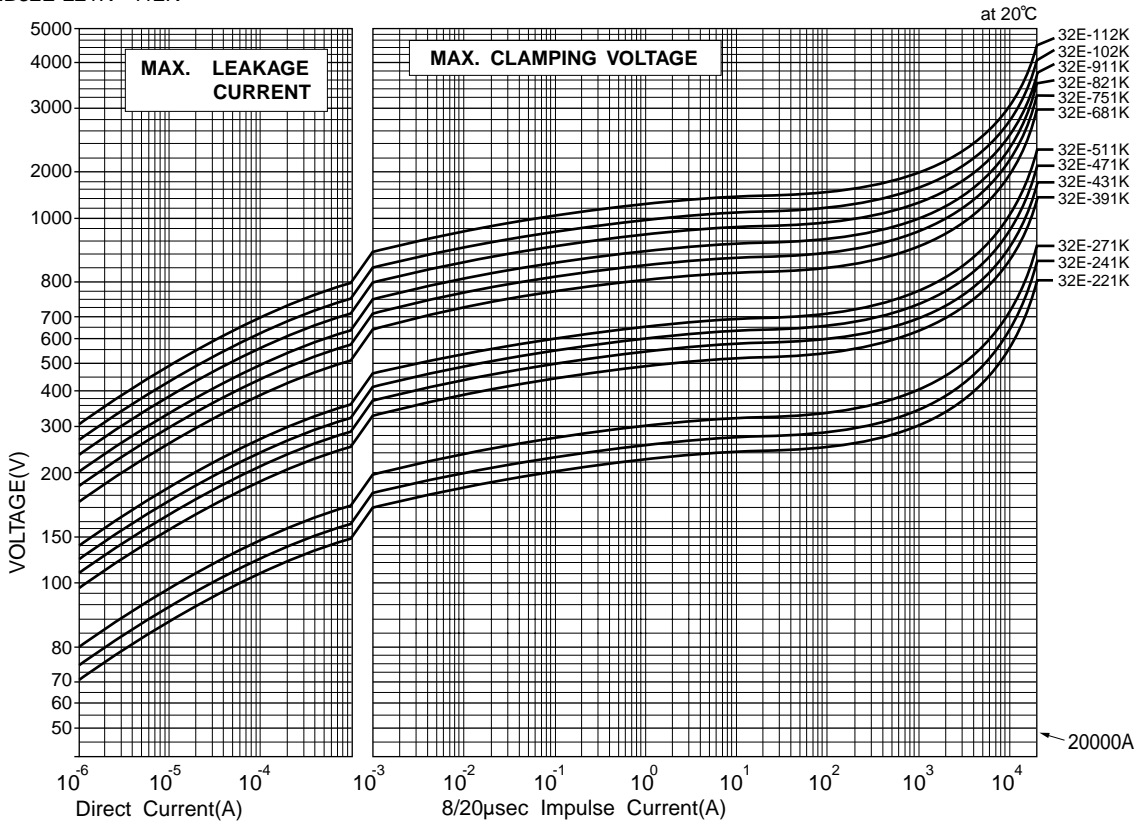

PULSE LIFE TIME RATINGS

When the following factors are different from the specified conditions, the peak pulse current should be revised based on the PULSE LIFE TIME RATINGS.

- Impulse duration time
- Number of impulse

(Impulse Current Wave Form)

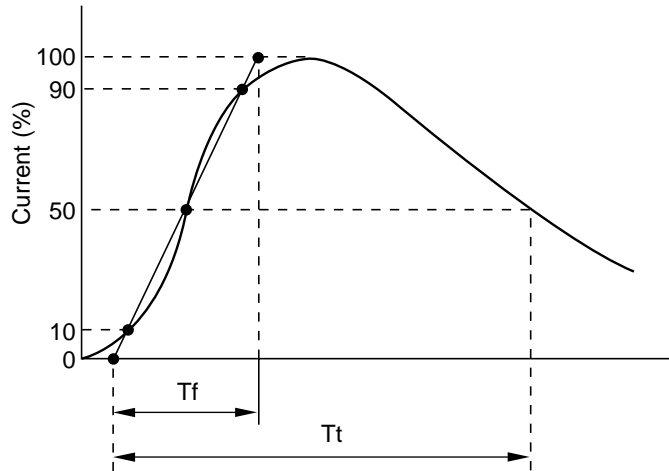

Tf : (Rise Time)

Tt : (Impulse Duration)

●V series

PULSE LIFE TIME RATINGS
(TND05V-180K~680K)

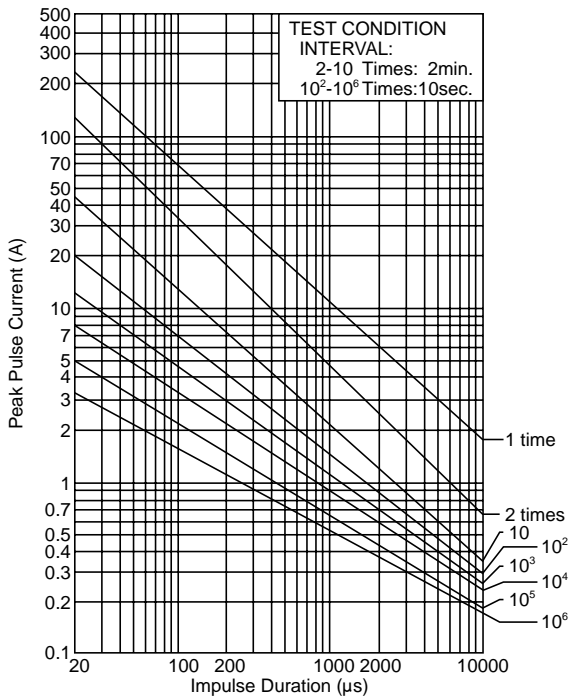

PULSE LIFE TIME RATINGS
(TND05V-820K~471K)

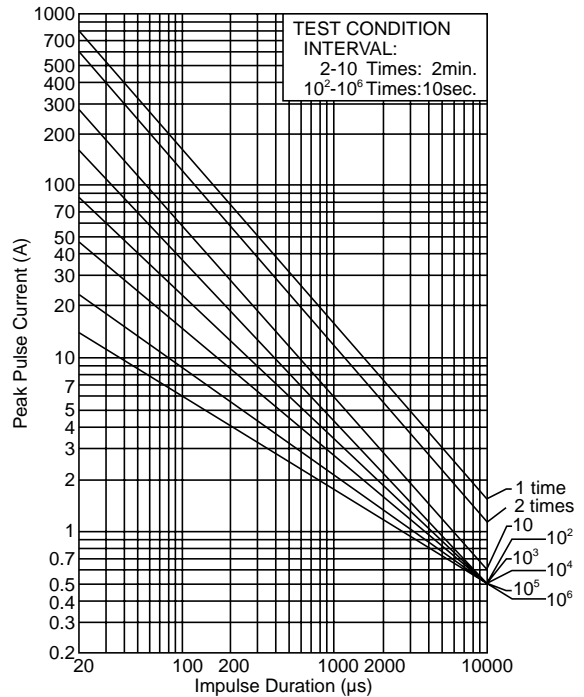

●V series

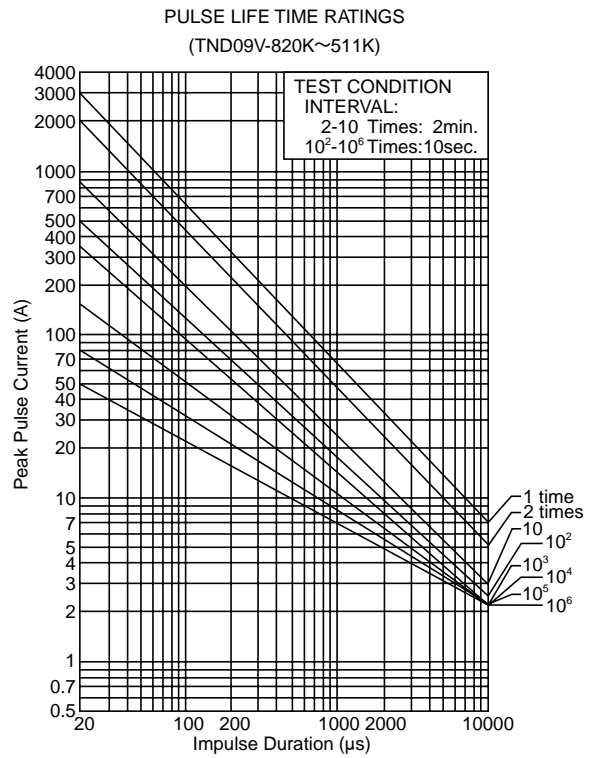
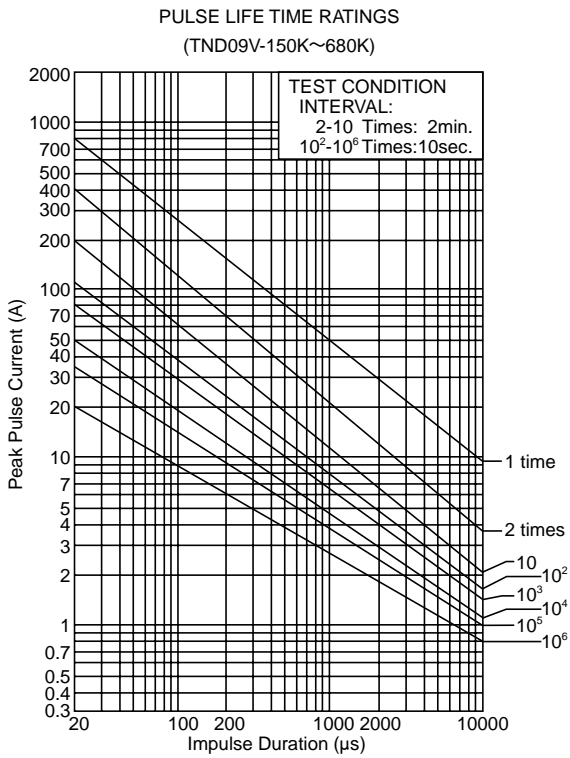
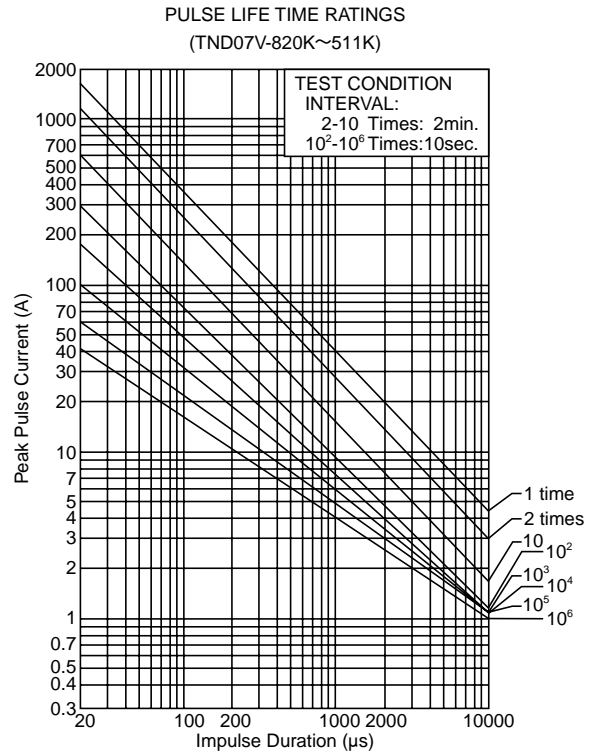
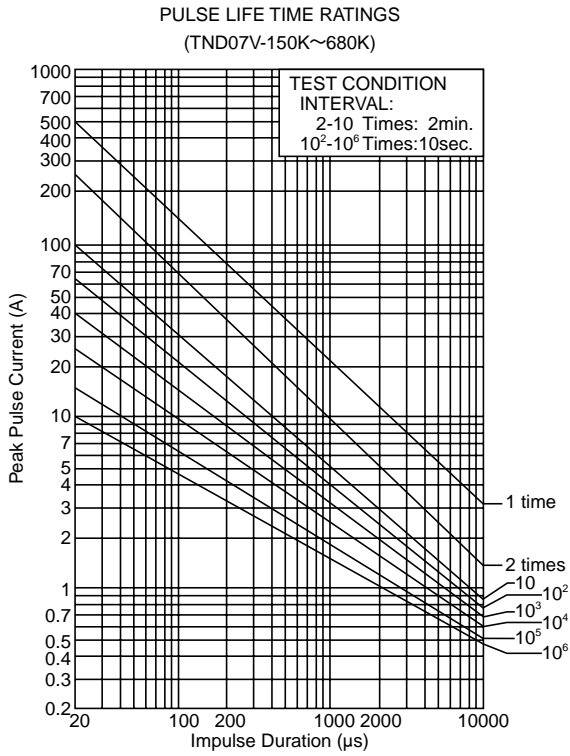

●V series

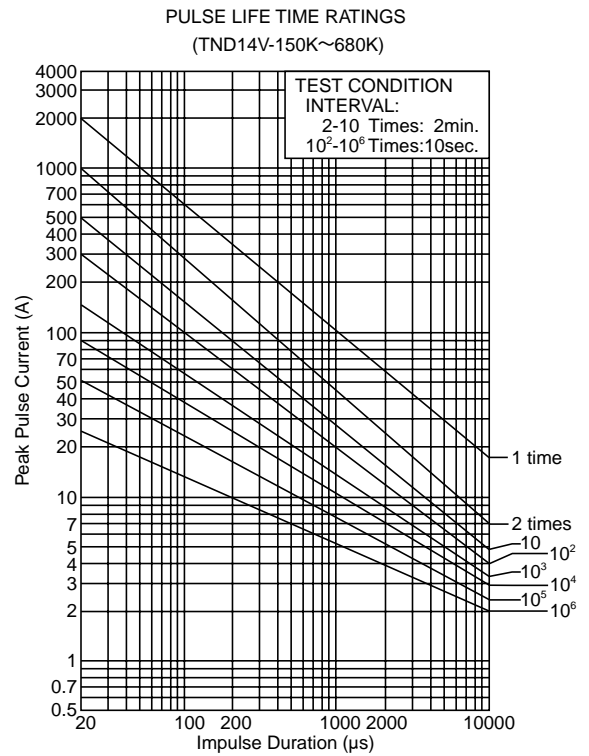
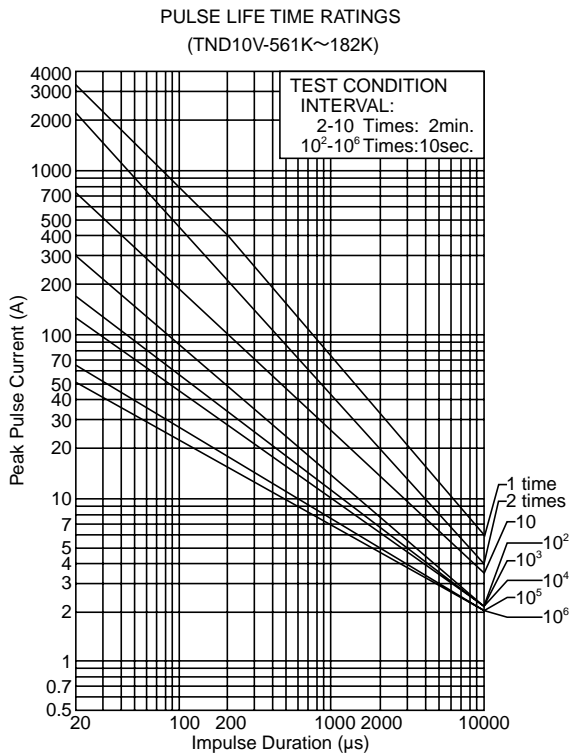
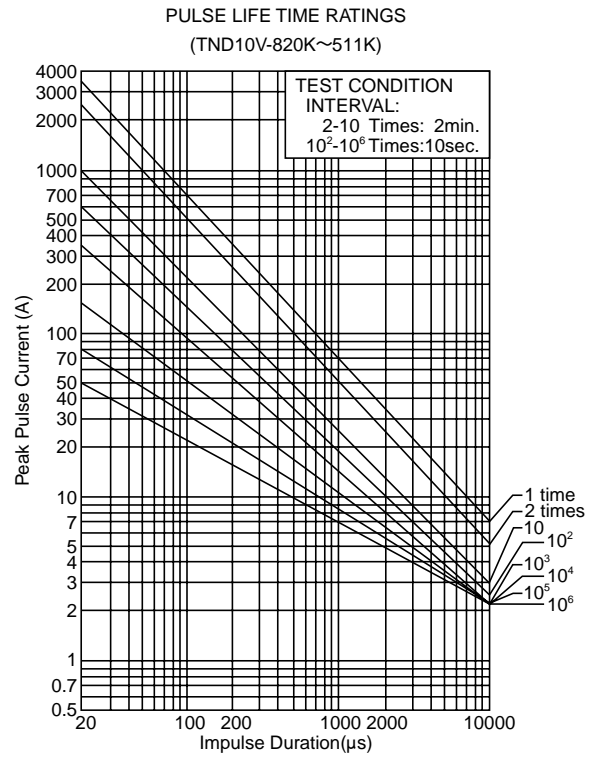
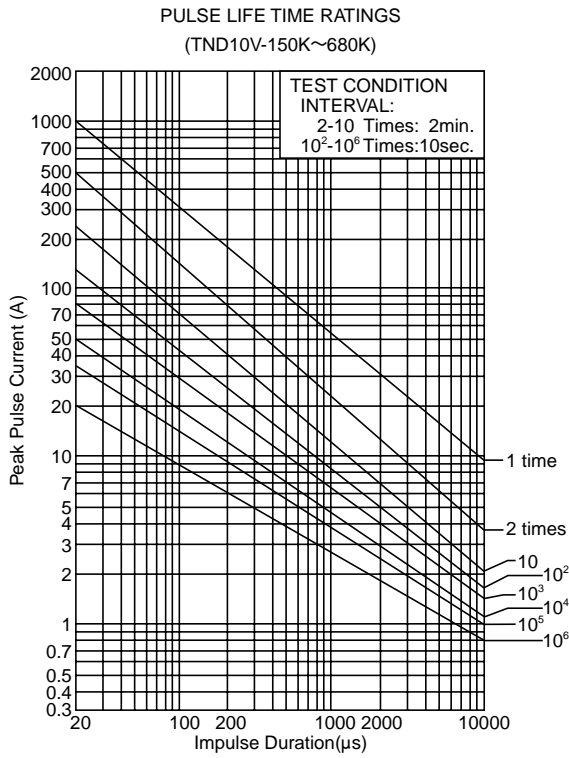

●V series

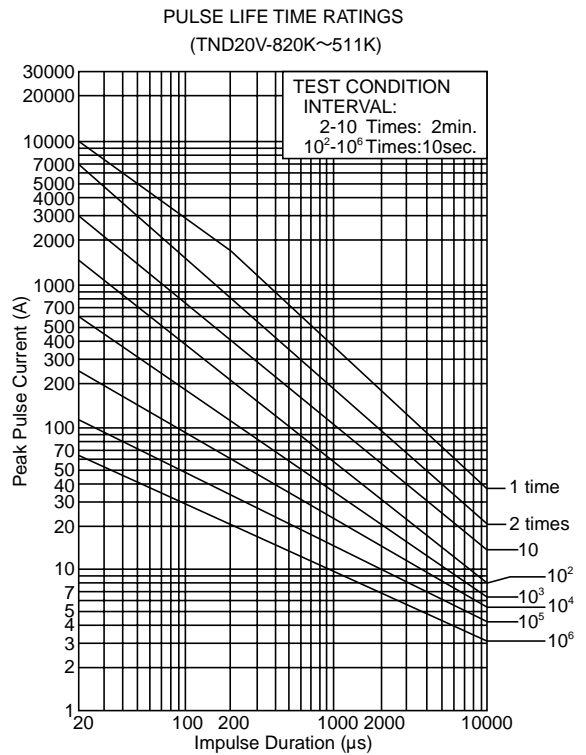
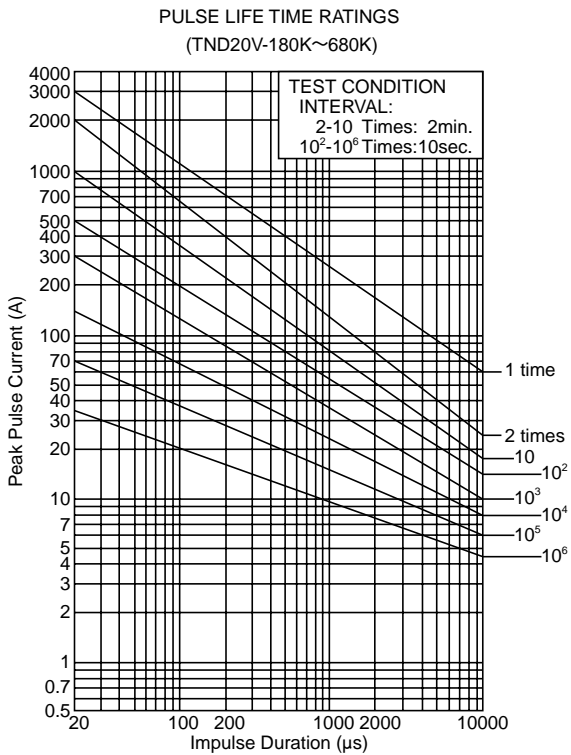
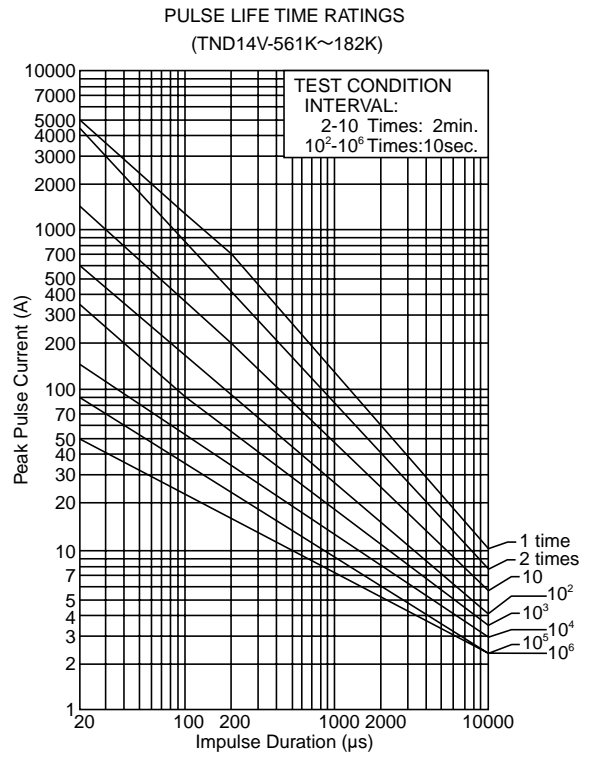
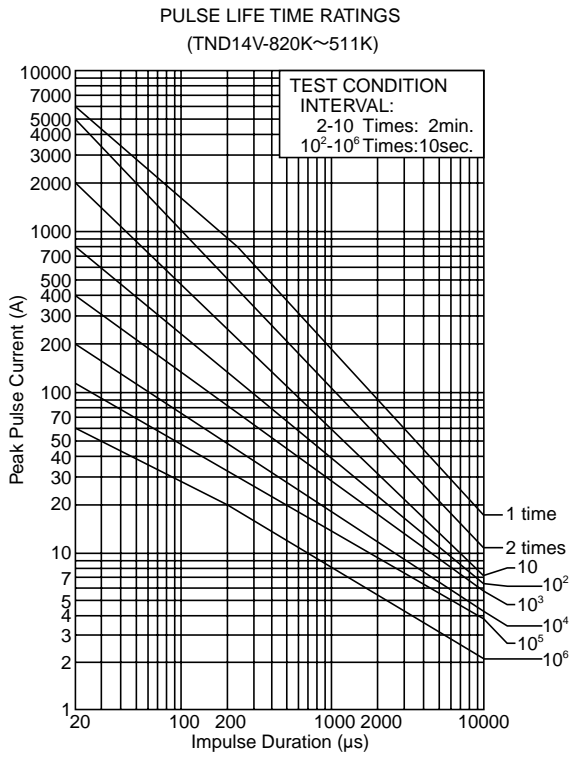

●V series

PULSE LIFE TIME RATINGS
(TND20V-561K~182K)

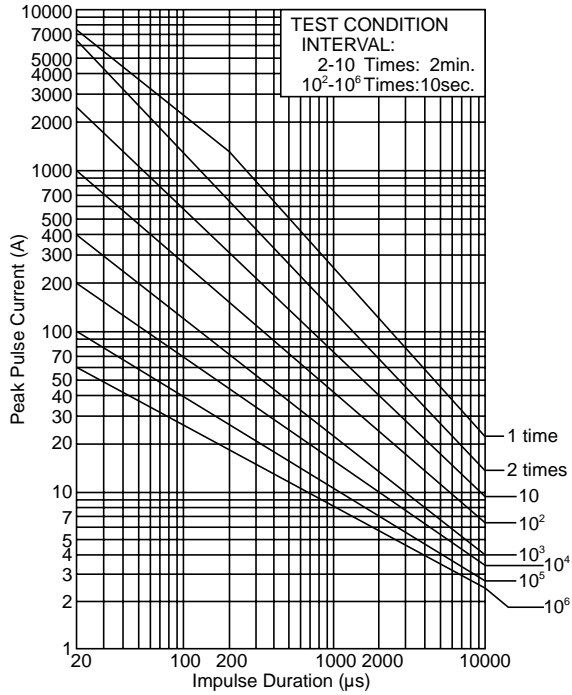

●32HP series

PULSE LIFE TIME RATINGS
(TNT32HP221K~112K)

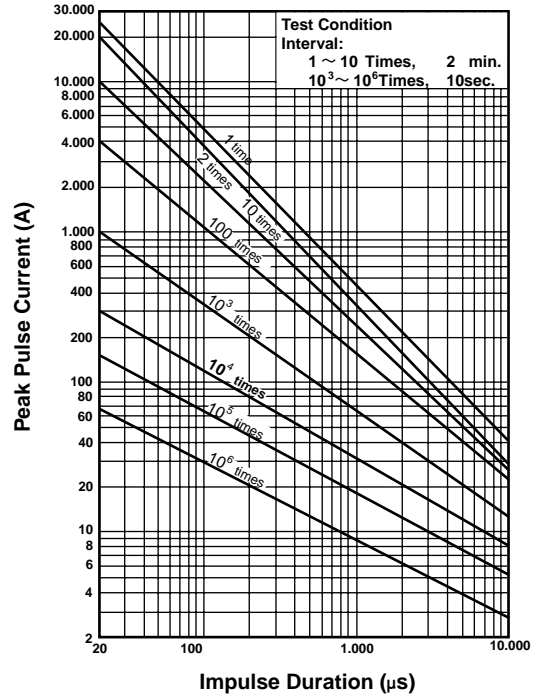

●C series

PULSE LIFE TIME RATINGS
(TNC05C-151K~271K)

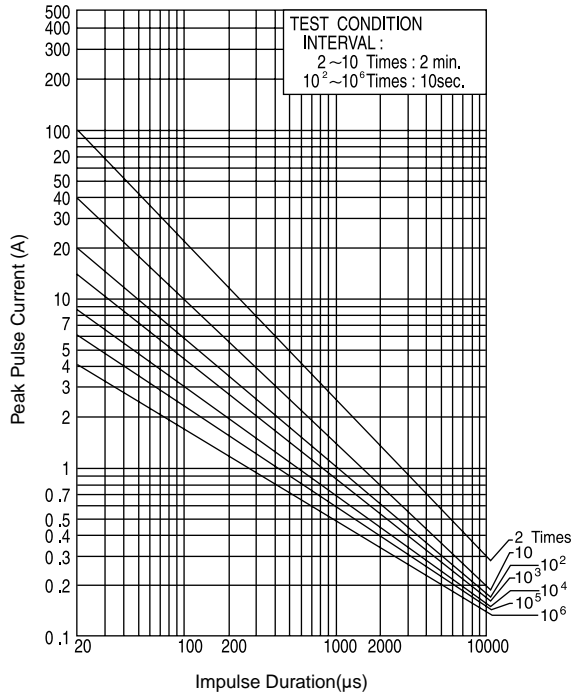

PULSE LIFE TIME RATINGS
(TNC07C-151K~471K)

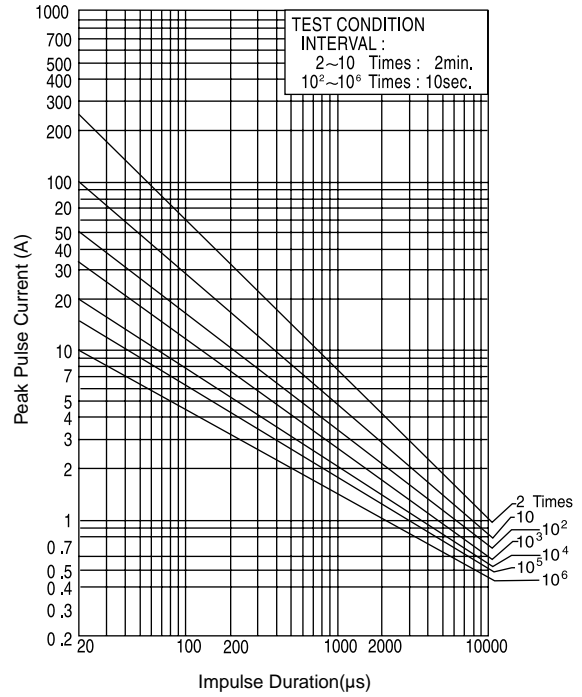

PULSE LIFE TIME RATINGS
(TNC09C-151K~471K)

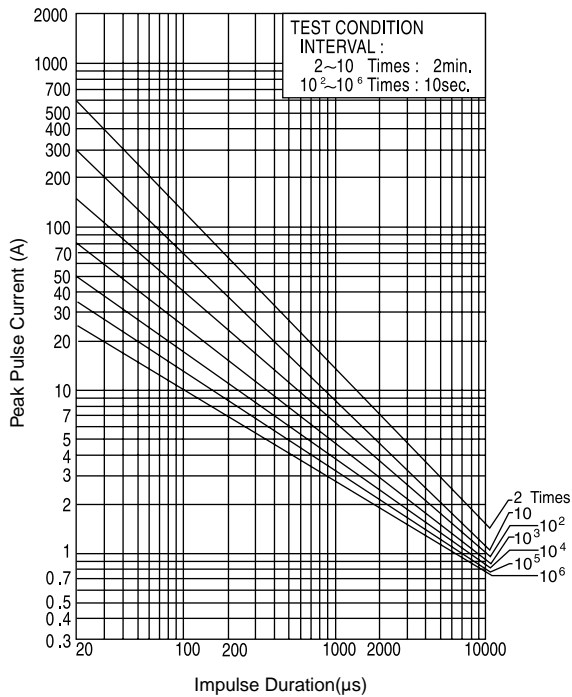

PULSE LIFE TIME RATINGS
(TNC12C-151K~471K)

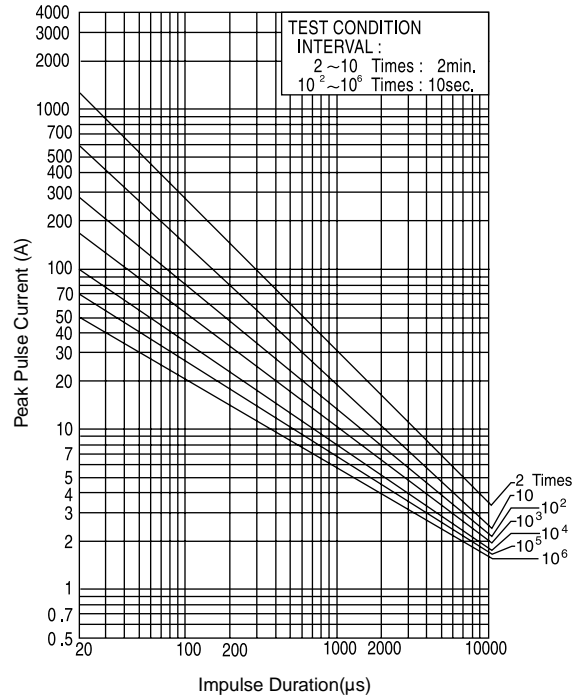

●A series

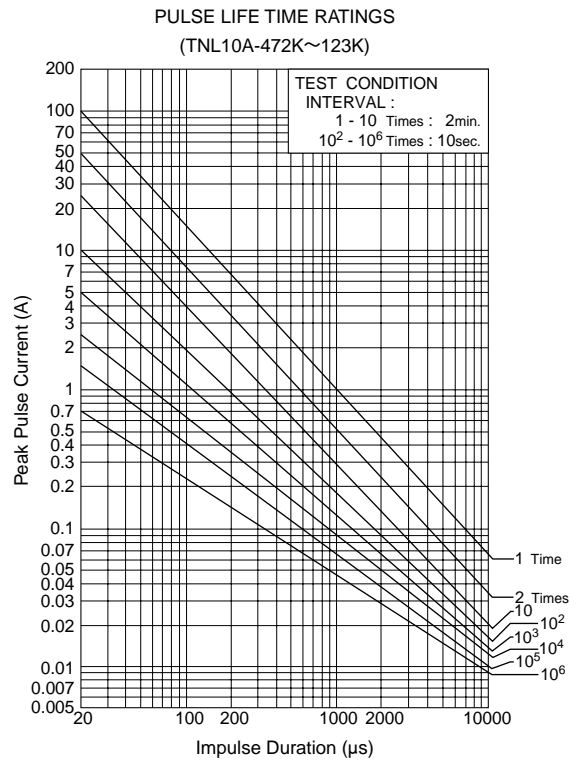
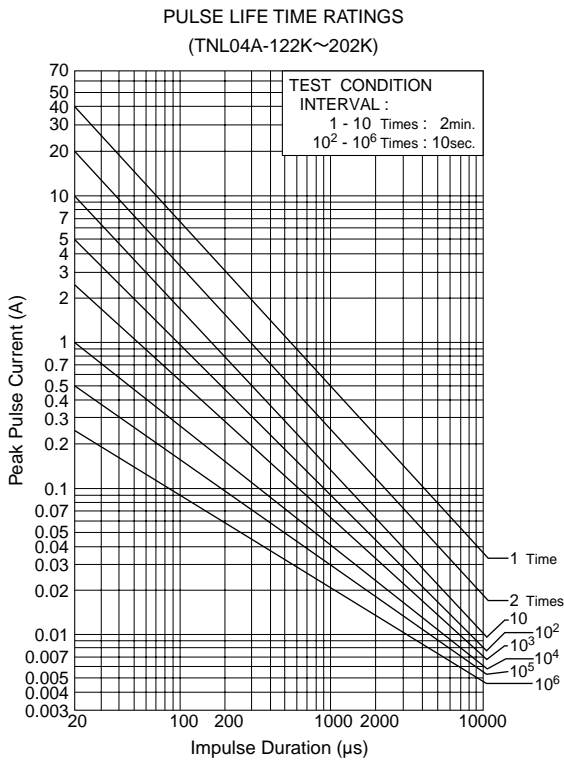

●E series

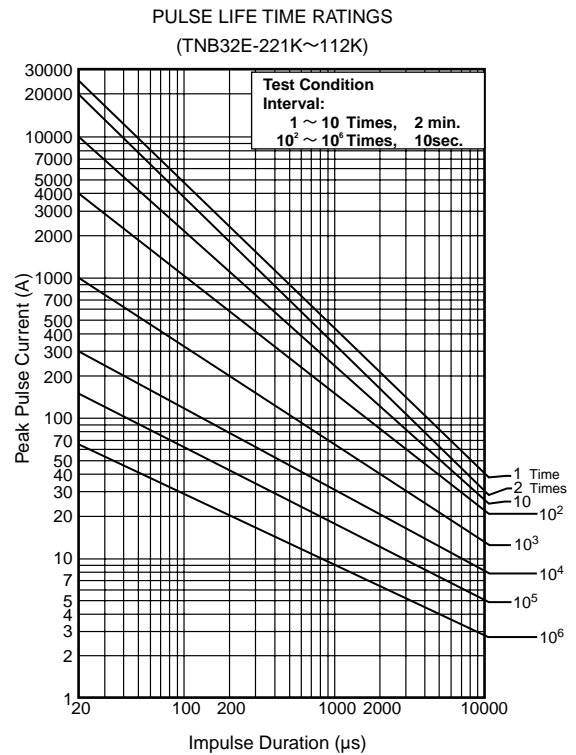
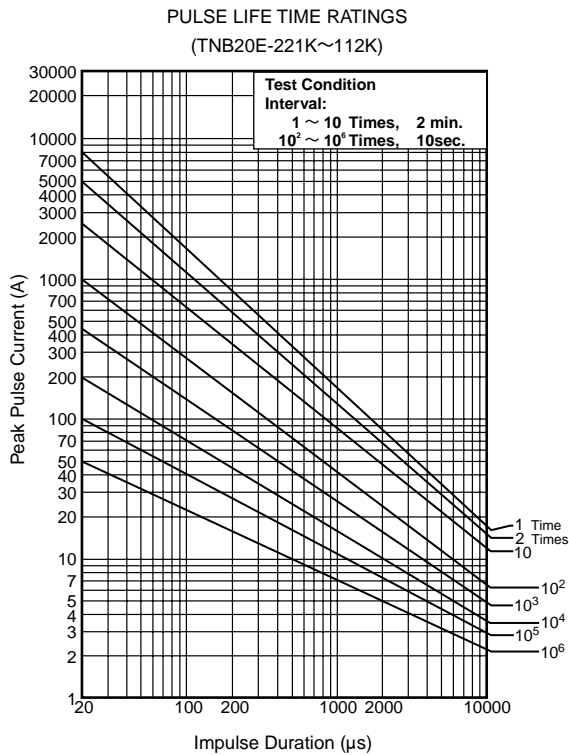

(1) Power Source Circuit

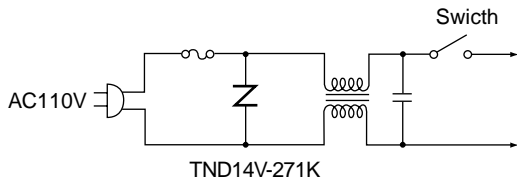

(2) Micro Computer Equipment

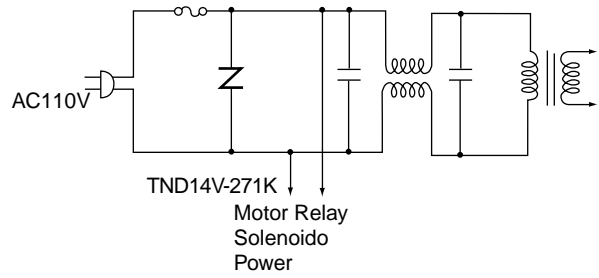

(3) Vending Machine

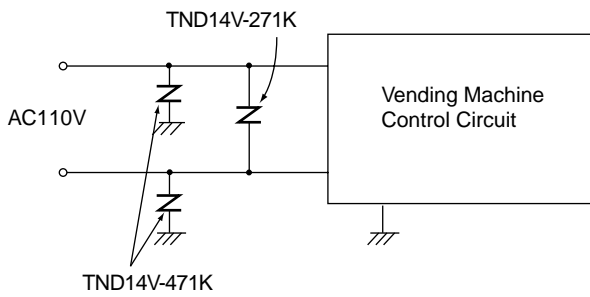

(4) Leakage Current Detector

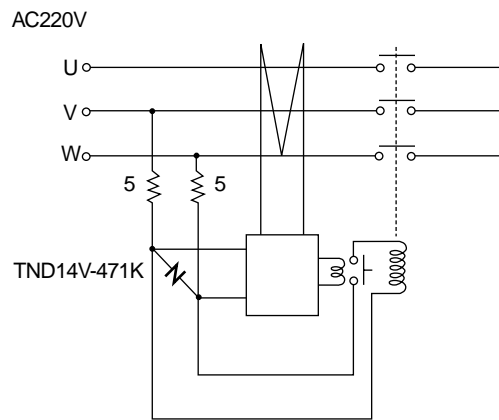

(5) Magnetic Brake

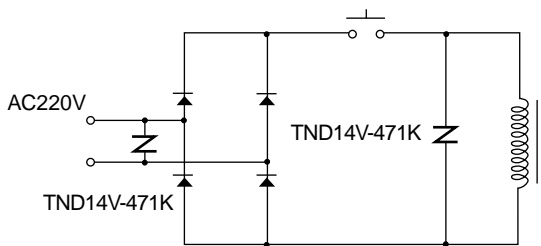

(6) Control of 20kW DC Motor

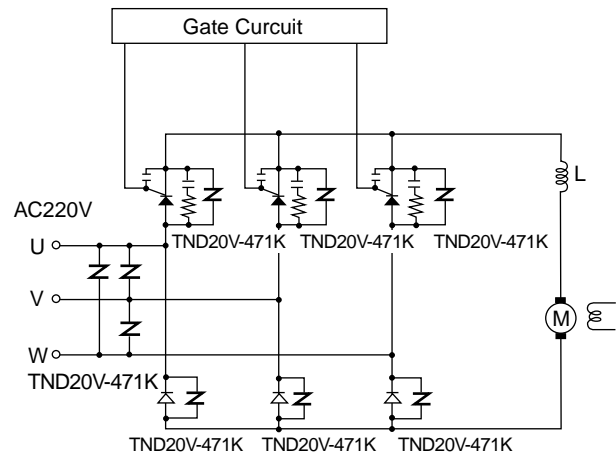

(7) Telephone

